



Designed to work. Safe to operate. Built to last.

Thermo-Lay makes the industry's safest, most effective, and easy-to-operate asphalt patching equipment. Each unit is designed and built in the USA by users with decades of experience in the asphalt patch truck manufacturing industry.

If you have any questions, please contact us at:

406-259-9525

1953 E. Commercial St., Meridian, ID 83642

www.thermo-lay.com | info@thermo-lay.com

For parts questions, please contact Parts@Thermo-Lay.com

Thank you for your business!

GENERAL INFORMATION

The Asphalt Thermo-Lay unit is designed for efficiently handling road asphalt materials at elevated temperatures. Users should have some knowledge of the materials used. The following information should be helpful to owners and operators of Thermo-Lay equipment.

Asphalt Road Mix consists of ASPHALT CEMENT, ROCK, and SAND ASPHALT CEMENTS. Asphalt cement serves as the fundamental material in the asphalt family. It is a semi-solid substance available in five different grades. These grades are used for creating hot mixes, penetration surface treatments, macadam for seal coats, and filling specific types of cracks.

During the early twentieth century, the standardization of asphalt cement grades led to the development of the penetration test as a method for specifying desired consistency ranges. In the mid-century, a more fundamental test, viscosity, started being used to determine the desired consistency ranges. Viscosity grades are identified by the prefix "AC" followed by a number indicating the material's viscosity. In the 1970s, an additional viscosity grading system was developed based on tests conducted on asphalt residue from the rolling thin film oven test. The grades in this system are designated by the prefix "AR" followed by a number indicating the viscosity of the material. In both the penetration grading system and viscosity grading system, higher grade numbers indicate higher viscosity (harder) asphalt.

RC, MC, AND SC ASPHALTS

Asphalt that is liquefied through blending with petroleum solvents is generally referred to as "cutbacks." When applied to roads or pavement, the solvent evaporates, leaving behind the asphalt cement. These types of asphalt come in two categories based on curing time: (1) rapid-curing (RC) containing a naphtha-like solvent, and (2) medium-curing (MC) containing a solvent similar to kerosene. The slow-curing (SC) type is not typically called a cutback as its solvent, which resembles heavy fuel oil, is not added but remains in the refining process. The SC type is sometimes referred to as "road oil" as well.

Each type is available in four viscosity-controlled grades, ranging from Grade 70 (containing the most solvent and being the most fluid) to Grade 3000 (containing the least solvent and being the least fluid or slowest pouring). A special grade, MC-30, is included in the medium-curing type and is predominantly used for prime coating and dust laying.

ASPHALT EMULSIONS

Asphalt emulsions are liquid mixtures containing asphalt cement, water, and an emulsifying agent. In an asphalt emulsion, tiny globules of asphalt are suspended in water. These emulsions are graded based on the time it takes for them to "break" or separate from suspension and are referred to as rapid-setting (RS), medium-setting (MS), and slow-setting (SS). When asphalt is in suspension, asphalt emulsions typically have a dark brown color, which turns black when the asphalt and water separate. Asphalt emulsions come in two types: anionic and cationic. In the anionic type, the asphalt globules have a negative electrical charge, while in the cationic type, the globules are positively charged. These electrical charge differences enhance the coating and bonding properties of the emulsion when used with aggregates that have surfaces oppositely charged.

CAUTION: DUE TO THE BLENDS IN ASPHALT OILS AND MIXES, VOLATILE VAPORS ARE RELEASED. AVOID EXPOSURE TO OPEN FLAMES.

ALL ABOUT RADIANT HEAT TRANSFER OIL

Your Thermo-Lay machine was shipped with Radiant Heat Transfer Oil. The Heat Transfer Oil is a "PURE" non-blended oil in the 68-grade class. The factory-installed Heat Transfer Oil has a flash point of approximately

500 degrees Fahrenheit. The Thermo-Lay machine is designed to heat and maintain a maximum temperature of 3500 degrees Fahrenheit (@ 10 P.S.I. with the burner supply and 110 gallons of heat transfer oil). Allowing the heat transfer oil level to drop below 110 gallons will cause the burner to raise the maximum temperature. It is of utmost importance to check the level of your heat transfer oil on a daily basis and add oil if the level drops.

The life expectancy of the Heat Transfer Oil depends on several factors, including the amount of oil, total heating time, ambient temperature, and the addition of non-compatible fluids. Your Thermo-Lay machine will operate more efficiently and have a longer lifespan if the following conditions are met:

- The Thermo-Lay machine has been purchased with a 9KW electric heater.
- The machine is wired to allow the electric heater to operate during the night.
- The thermostat is set at the ideal temperature for the asphalt mix in the hopper.
- The Thermo-Lay machine is stored in a location where the highest ambient temperature can be maintained.

It is the responsibility of each owner to ensure that their Thermo-Lay unit always maintains a minimum of 110 gallons of heat transfer oil (the lowest mark on the dipstick. **THERMO-LAY MANUFACTURING, LLC. WILL PROVIDE WARRANTY COVERAGE FOR THE MACHINE ONLY IF THE FOLLOWING RULES ARE FOLLOWED:**

1. Heat transfer oils to be installed must be Shell Turbo 68, Conoco Heat Transfer Oil, Chevron Heat Transfer Oil #1, Exxon Heat Transfer Oil, or an equivalent oil approved by the factory.
2. These transfer oils must be sampled at 50 hours, 150 hours, 250 hours, 500 hours, and every hundred hours thereafter to determine the acidity level and breakdown of the oil. These samples can be sent to the oil supplier for analysis. When the Heat Transfer Oil reaches a total acid number of 4.0, the oil must be replaced with new oil having an acid number of 0.25.
3. The transfer oils must not remain in the machine beyond 3000 hours without sampling.
4. Any oil that becomes dark and non-transparent before the 3000-hour mark must be replaced.
5. A minimum of 110 gallons of transfer oil must be maintained in the unit.
6. The transfer oils must be checked daily to ensure the proper oil level and should not be allowed to fall below the lowest mark on the Dip Stick Level Indicator.

The life of the transfer oil may exceed 3000 hours, and it can be kept in the machine beyond the 3000-hour mark. However, if the oil reaches an acid level of 4.0, it will void the warranty for the burner retort tube and associated heating parts. The extended hourly period can be determined based on the acidity level of the oil when sampled.

Failure to maintain 110 gallons of heat transfer oil in the machine, failure to install the recommended heat transfer oil, or failure to replace the heat transfer oil after reaching an acid number of 4.0 may result in severe damage to the machine and potential harm to operating personnel.

If you have any questions regarding the Thermo-Lay machine, Heat Transfer Oil, Electric Heater, or related warranty, please don't hesitate to contact the factory at 406-259-9525.

PRE-START-UP INSTRUCTIONS

Before operating the machine, the following checks and procedures must be completed:

1. Read the Thermo-Lay operating manual thoroughly to familiarize yourself with the machine and its operation.
2. Check the oil level in the hydraulic reservoir by observing the sight glass under the left fender at the hydraulic tank. This sight gauge also functions as a thermometer. The hydraulic oil temperature should never exceed 120 degrees Fahrenheit. Always operate the machine with the oil level visible in the sight glass. The capacity of the hydraulic reservoir is 30 gallons, and it is filled with SW-20 hydraulic oil. It is recommended to use this oil or a factory-approved alternative. Whenever possible, use petroleum-based oil. Avoid using oils with detergents or additives like naphtha. Only add clean hydraulic oil from clean containers and keep the fill cap on the reservoir.

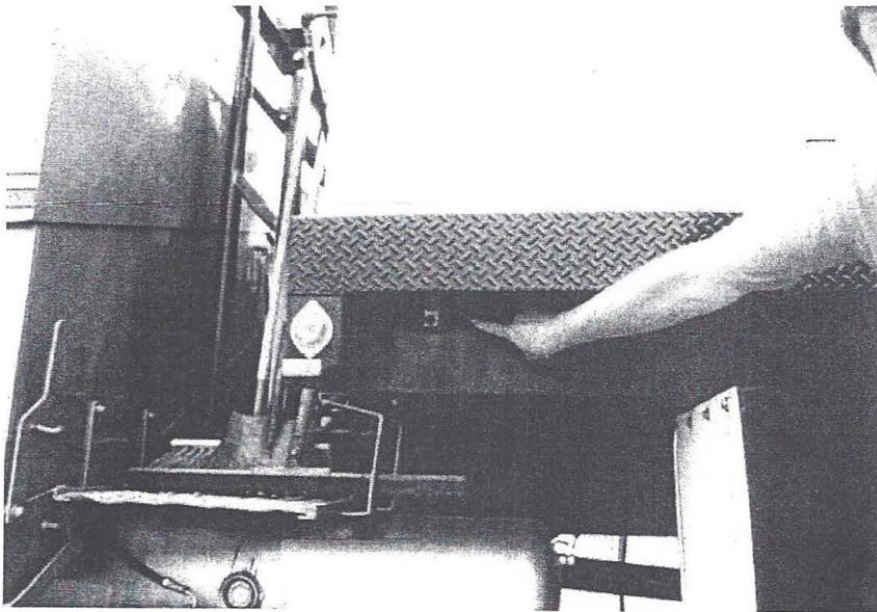

3. Ensure that all bearings are properly greased. The Thermo-Lay unit has eight locations that require grease, as listed below:

- Rear Conveyor Bearing
- Front Conveyor Bearing
- Front Anti-Bridge Bar
- Center Anti-Bridge Bar
- Rear Anti-Bridge Bar
- Sander Shaft Bearing (if applicable to model)
- Sander U-Joint (if applicable to model)
- Front Hydraulic Pump U-Joint

PLEASE NOTE THAT THESE BEARINGS ARE GREASED AT THE FACTORY BEFORE THE UNIT IS SHIPPED.

4. Verify the level of the Radiant Heat Transfer Oil by removing the Dip Stick Level Indicator located on the passenger's side at the rear of the machine. It is crucial to NEVER operate the machine with less oil than the lower mark indicated on the dipstick.

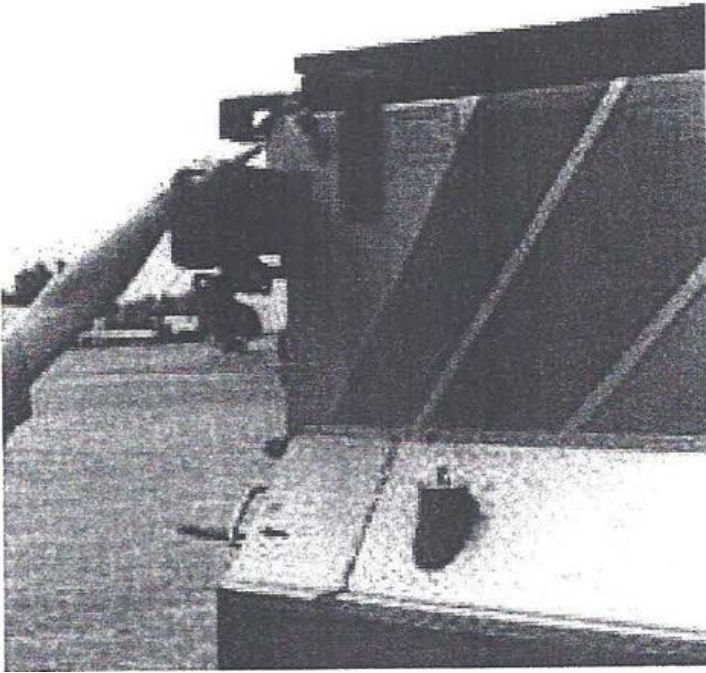

5. Fill the cleaning fluid tank with a release agent. This tank should be filled up daily so that enough cleaning fluid is available to keep the system clean.

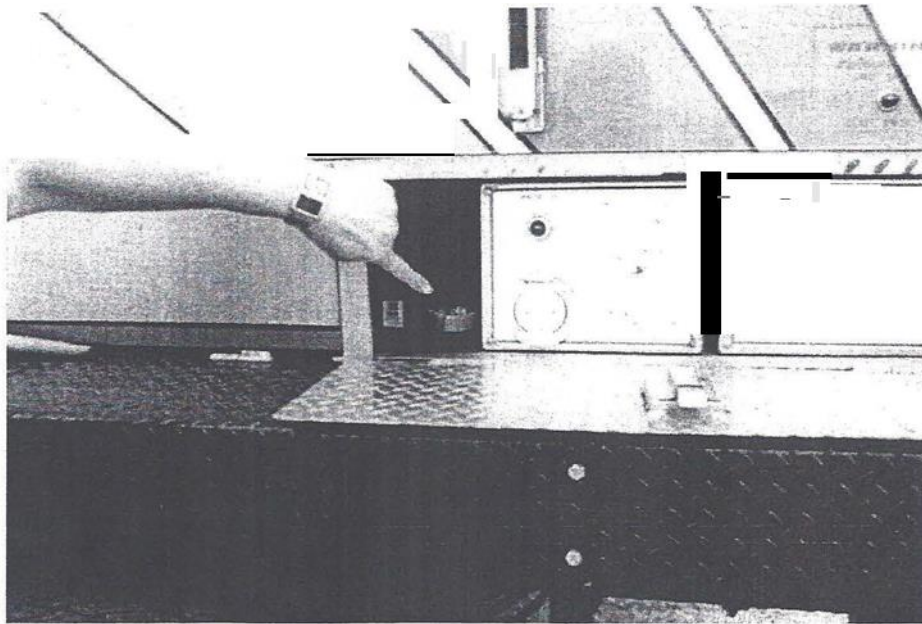

WARNING:

Turn the "PROPANE BURNER SWITCH" to "OFF" before attempting to fuel or refuel.

- Fill the propane tank with propane fuel. The Thermo-Lay machine will have either a 100# vertical bottle or a built-in 34-gallon horizontal tank. Both containers can be filled without having to be removed. Both are filled with LIQUID propane gas, and both produce VAPOR propane gas.

WARNING: Turn the "PROPANE BURNER SWITCH" to "OFF" before attempting to fuel or refuel.

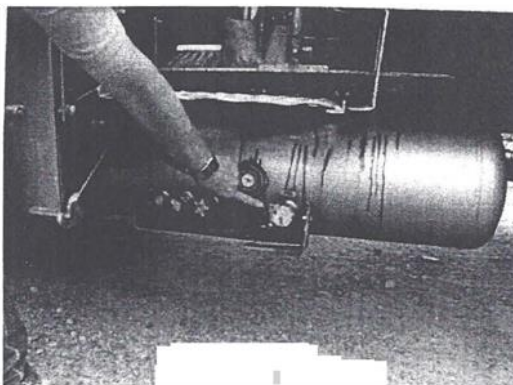

- If your unit is equipped with a separate gasoline or diesel engine, fill the tank daily and check the oil level in the engine and add as needed.

WARNING: Turn the "PROPANE BURNER SWITCH" to "OFF" before attempting to fuel or refuel.

- Check the tack oil level by removing the Tack Oil Dipstick Level Indicator located on the passenger side of the machine and add as needed. It is advisable to keep ONLY 2 days' worth of tack oil in the tack oil tank.

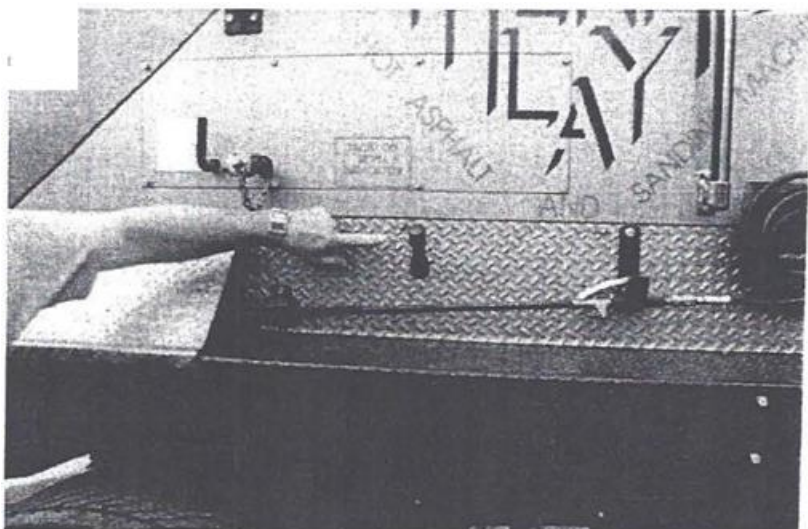

CAUTION: Be extremely careful when adding hot asphalt oils to the tank, hot oil in contact with a colder material could cause thermal expansion of the product resulting in oil overflow.

THE PROCEDURE FOR FILLING THE ASPHALT AGGREGATE HOPPER IS AS FOLLOWS:

- Begin by filling the hopper with just enough sand to cover the screw conveyor during the first load only.
- Once the sand is loaded, dispense it out of the hopper.
- Next, fill the hopper with the asphalt mix while engaging the screw conveyor.
- It is important to run the screw conveyor long enough to allow the sand to fill in under the screw conveyor. Failure to do so during the first load may result in serious damage to the screw conveyor.
- Prior to each load, it is imperative to spray the hopper with a release agent to lubricate the heating surfaces. This is necessary to ensure smooth operation and prevent material from sticking to the sides of the unit, which can hinder the proper feeding of the auger.

The Thermo-Lay machine is not designed to mix road oils and aggregates. Therefore, pre-mixed material must be used. The oil content in the mix will affect the machine's operation. Excessively high oil content can cause the mix to pack around the screw conveyor, making it difficult to dispense. The aggregate should not exceed a size of 3/4" and should be free of large rocks and other foreign objects. Using a smaller aggregate size can result in better patches but using too fine of an aggregate can also lead to packing issues. Thermostat settings for the machine will vary depending on the type of oil used. It is recommended to consult local oil suppliers or contact **Thermo-Lay Manufacturing at (406)259-9525** for guidance on achieving the desired operating temperature.

START-UP INSTRUCTIONS

LOADING TACK OIL

The Thermo-Lay machine is specifically designed for storing, transporting, and dispensing cut-back or emulsion tack oil. It is NOT designed for use with asphalt cement. The tack oil tank has a capacity of 120 gallons, but it is highly recommended to keep a maximum of 2 days' worth of tack oil in the tank at any given time. If tack oil is left in the tank for an extended period, it may start to "set up" and solidify, which would require thorough cleaning to restore the tank's storage capability.

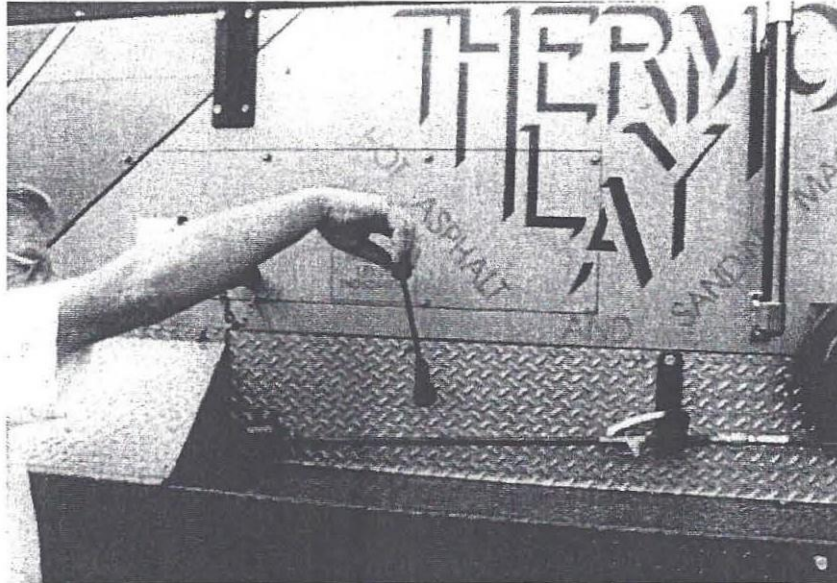

WARNING: BEFORE ATTEMPTING TO FILL THE TACK OIL TANK WITH TACK OIL, ENSURE THAT THE TACK OIL DIPSTICK LEVEL INDICATOR IS REMOVED TO ALLOW INCOMING PRESSURE TO VENT. FAILURE TO DO SO MAY RESULT IN DAMAGE TO THE TANK AND CAUSE BODILY INJURY TO THE LOADING OPERATOR!!!

1. There are three methods for filling the tack oil tank:

(a) If you have the optional loading kit, remove the protective fill cap and install the fill hose. Turn the optional "FILL" valve to the "LOAD" position. Push the rear valve handle IN to the "TACK OIL" position. Move and hold the "SPRAY, CLEAN, LOAD" switch to the "LOAD" position. Please note that this switch will not stay in the "LOAD" position and must be kept in this position.



(b) Push the rear valve handle into the "TACK OIL" position. Move and hold the "SPRAY, CLEAN, LOAD" switch to the "LOAD" position. Please note that this switch will not stay in the "LOAD" position and must be kept in that position manually.

(c) Remove the 3" fill cap located on the passenger side of the machine near the front. Fill the tack oil tank either by pouring the tack oil in or by pumping from another source.

Note: It is essential to clean the pump, hose, and wand after loading the tack oil tank using the first two methods. Failure to clean the system will result in damage to the tack oil system.

LOADING ASPHALT MIX INTO THE HOPPER

Before loading asphalt mix into the hopper, it is mandatory to fill the void under the screw conveyor with some form of material, such as sand or existing asphalt from a previous load.

1. Open the hopper doors.
2. Fill the hopper with asphalt mix, ensuring that the material does not exceed the internal fill line to comply with GVWR and applicable safety requirements.
3. Before closing the hopper doors, ensure that the asphalt mix is not loaded in a way that obstructs the closing of the doors. The hopper doors do not exert enough pressure to level an excessive amount of asphalt. If there is excess asphalt mounded up in the hopper, it must be leveled off by hand before closing the hopper doors. Close the hopper doors.

WARNING: BEFORE CLOSING THE HOPPER DOORS, ENSURE THAT NO PERSONNEL IS INSIDE THE HOPPER. FAILURE TO DO SO MAY RESULT IN SEVERE BODILY INJURY.

If tack oil is left in the tank for an extended period, it may start to "set up" and solidify, which would require thorough cleaning to restore the tank's storage capability.

HEATING INSTRUCTIONS

Before dispensing any material from the Thermo-Lay machine, it is crucial to ensure that the radiant oil temperature is appropriate for the asphalt mix loaded in the hopper. The temperature of the mix determines the temperature the radiant oil must reach for the screw conveyor to dispense the mix effectively.

If using "COLD MIX," refer to the "GENERAL INFORMATION" section of the manual under the subheading "ASPHALT CEMENTS." There, you will find charts indicating the temperature range necessary for spraying cold-mix asphalt cement. The radiant oil temperature must be at least in the middle of the temperature range specified in these charts.

If using "HOT MIX," consult your asphalt supplier to determine the temperature of the mix when it is dispensed from the hot mix plant. The radiant oil temperature must be at least at this temperature before attempting to dispense the material.

WARNING: Attempting to dispense asphalt mix from the machine without the radiant oil at the proper temperature will result in damage to the machine.

The Thermo-Lay machine is heated using a propane gas heating system. This system is supplemented by a 9 KW (50 AMP) - 240-volt electric heater, which provides heat during non-operating hours. Keeping the heating system at a constant temperature will facilitate smoother operation, prolong the machine's lifespan, and extend the life of the heat transfer oil. Failure to use the electric heater as a supplemental heat source will lead to longer start-up times, difficulties in dispensing asphalt mix, and shorter heat transfer oil life.

TO IGNITE THE PROPANE BURNER:

1. Open the main propane gas valve located at the propane tank.
2. Set the thermostat to the desired temperature, matching the temperature of the mix from the batch plant.
3. Turn the "BURNER ON-OFF" switch to the "BURNER ON" position.

The propane burner is designed to ignite at a low flame for 10 seconds and then transition to a high flame. It will shut off when the desired temperature is reached and automatically reignite when the temperature drops.

TO SHUT OFF THE PROPANE BURNER:

1. Turn the "BURNER ON-OFF" switch to the "OFF" position.
2. Close the propane bottle gas valve.

If the propane burner shuts off for any reason, leaving the "RED" reset light flashing three times, wait approximately three seconds before reigniting the burner. This allows the electronic circuit to reset itself.

Transporting the unit while the burner is operating is at the user's discretion. However, caution must be taken not to have the Thermo-Lay burner switch in the "ON" position during refueling or near gasoline furnaces or refueling facilities due to the burner system's frequent re-ignition feature. Decisions on transporting with the burner on or off should consider prevailing wind conditions. While the Thermo-Lay propane burner can operate during transport, wind turbulence may cause the burner to shut down.

WARNING: ENSURE TO TURN THE "BURNER ON-OFF" SWITCH TO THE "OFF" POSITION WHEN REFUELING TO AVOID FIRE, EXPLOSION, DAMAGE TO THE MACHINE, PERSONAL INJURY, BODILY INJURY, OR DEATH. TURN THE SWITCH TO "OFF" WHEN APPROACHING ANY LOCATION WHERE FUELING IS BEING PERFORMED.

TO OPERATE THE ELECTRIC HEATER:

1. Make sure the 50 AMP breaker switch, the incoming source, is in the "OFF" position.

2. Leave the thermostat at the desired temperature.
3. Plug the connector in and twist it to ensure a tight connection.
4. Turn the 240-volt electric heater switch to the "ON" position.
5. Verify that the amber "POWER ON" light is lit. This indicates that power is supplied to the heating element.

NOTE: If the amber "POWER ON" light does not light when the switch is in the "ON" position, it may indicate that the radiant oil temperature is not below the desired temperature. Once the radiant oil cools below the desired temperature setting, the thermostat will engage the electric heater, and the amber "POWER ON" light will illuminate.

TO DISCONNECT THE ELECTRIC HEATER:

1. Disconnect power at the breaker switch from the power source away from the Thermo-Lay.
2. Turn the 240-volt electric heater switch to the "OFF" position.
3. Twist and unplug the connector.

The 9 KW electric heater is designed to provide supplemental heat during non-operating hours. While it can be used to dissolve old used asphalt overnight, the electric heater will maintain the radiant oil temperature at 250 degrees Fahrenheit above the ambient temperature. The appropriate temperature setting for keeping the hot mix in the hopper overnight or for extended periods depends on the asphalt cement in the hot mix. **IT IS NOT ADVISABLE TO STORE ANY ASPHALT MIX IN THE HOPPER OVERNIGHT THAT MAY CONTAIN ADDITIVES SUCH AS RUBBER, PORTLAND CEMENT, FLY ASH, RECYCLED ASPHALT MIX, OR OTHER FILLERS COMMONLY USED TO AID IN SETTING THE ASPHALT MIX. LEAVING SUCH ASPHALT MIX IN THE HOPPER OVERNIGHT MAY CAUSE DAMAGE TO THE MACHINE AND REQUIRE CHIPPING OUT ONCE IT SOLIDIFIES.**

NEW ROUND-STYLE CLOCK TIMER

1. For proper installation, refer to the wiring diagram located at the back of the unit.
2. Press the RESET button before using the timer.
3. Replace the battery if the display window does not show any readout.

Button Instructions:

- CLOCK: Used to set the current time.
- TIMER: Enters the Program Mode for setting ON and OFF programs.
- DAY: Sets the day of the week.
- HOUR: Sets the hour.
- MINUTE: Sets the minutes.
- MANUAL: Used to select ON/AUTO/OFF modes.
- P (Reset Button): Press to cancel all prior settings.
- ON: LED lamp indicator that lights up when the device is turned on.

To Set the Current Day and Time:

1. Press and hold the "CLOCK" button while pressing the "DAY" button until the current weekday is selected.
2. Press and hold the "CLOCK" button while pressing the "HOUR" button until the current hour is selected.
3. Press and hold the "CLOCK" button while pressing the "MIN" button until the current minute is selected.
4. After setting the weekday and time, the seconds will automatically reset.

To Program ON/OFF and Daytimes:

1. Press the "TIMER" button. "1 ON" will be displayed at the bottom left of the screen.
 - You can set "Program 1 ON" options for when you want the device to be turned on.
2. Press the "DAY" button to select the program period. There are 10 options available.

- Use the corresponding numbers to select the desired day(s).
- 3. Press the "HOUR" button to set the hour for the program.
- 4. Press the "MIN" button to set the minute for the program.
- 5. After setting the "1 ON" program, press the "TIMER" button. "1 OFF" will appear.
 - You can now set "Program 1 OFF" options for when you want the device to be turned off.

Reviewing Your Programs:

1. Press the "TIMER" button to review each "ON" and "OFF" program setting.
2. After reviewing the days and times for each program, adjust as needed following the instructions.

The "MANUAL" button:

1. Press the "MANUAL" button to select either "ON," "AUTO," or "OFF" mode.
2. "AUTO" mode enables the timer programs to activate.
3. To turn the device on until the program starts, cycle through the options from "ON" directly to "AUTO."
4. To turn the device off until the program starts, cycle through the options from "OFF" directly to "AUTO."
5. To leave the device in either the ON or OFF positions, select "ON" or "OFF" accordingly.

If the display window is not showing any readout, replace the battery.

PATCHING INSTRUCTIONS

THE REPAIR SITE

To perform patching using the Thermo-Lay machine, follow these instructions at the repair site:

1. Check the temperature of the radiant heat transfer oil. It must be the same temperature as the mix when it was delivered from the batch plant.
2. Position the machine in front of the repair section.
3. Engage the Power Take Off (PTO) to supply hydraulic power to the Thermo-Lay machine.
4. Turn on the truck's 4-way flasher, arrow board, and strobe light to ensure visibility.
5. Use cones, barricades, and traffic markers to direct traffic flow around the truck and the repair area.
6. Clean the area to be repaired with a broom and square up the sides of the repair area using the hydraulic breaker. Cut away the defective material until the edge of the repair section is surrounded by good stable asphalt.

TO OPERATE THE HYDRAULIC BREAKER:

- a) Engage the power take-off.
- b) Place the asphalt cutting spade or 6" tamping shoe in the breaker for compacting.
- c) Connect the hydraulic hoses to the hydraulic breaker, starting with the large RETURN hose followed by the smaller PRESSURE hose. This order prevents pressure from being trapped in the breaker. When disconnecting the hydraulic breaker, disconnect the small PRESSURE hose first, followed by the larger RETURN hose.
- d) Move the "TOOL" switch to the "OPERATE" position.

NOTE: ENGINE RPM DOES NOT EQUATE TO MORE HORSEPOWER. PRESSURE IS DETERMINED BY THE INTERNAL CLEARANCES IN THE PUMP AND REMAINS CONSTANT AT ANY RPM, WHILE FLOW INCREASES WITH RPM.

- e) Depress the operating handle on the hydraulic breaker. The breaker has a pressurized cartridge inside that moves downward to propel the cutter or tamper into the asphalt. However, additional downward force (provided by your body weight) is required for deep penetration. The more weight applied, the better the penetration. The breaker's class size also affects penetration, with a larger class breaker providing more force than a smaller class breaker.
- f) After cutting, tamping, and cleaning the repair section, move the "TOOL" switch back to the neutral position.
- g) Place the breaker back on the lift platform holder and disconnect the hoses, starting with the PRESSURE hose first, followed by the RETURN hose.

TO CONTINUE THE PATCHING PROCESS USING THE THERMO-LAY MACHINE, FOLLOW THESE INSTRUCTIONS:

- 7) If there is moisture present, dry the repair area using a propane hand torch.

OPERATING THE HAND PROPANE TORCH:

- a) Remove the hand propane torch from its holder.
- b) Move the hand propane switch to the "ON" position.
- c) While holding a striker near the burning end, slowly open the shut-off valve located at the hose end of the torch. Open the valve after the flame is established.

NOTE: EXERCISE CAUTION WHEN HANDLING PROPANE AND FOLLOW SAFETY GUIDELINES TO PREVENT ACCIDENTS OR INJURIES.

- 8) Spray tack oil into the repair section, coating the bottom of the repair and the sides of the existing asphalt.

USING THE TACK OIL SPRAY SYSTEM:

- a) Push the "TACK\CLEAN" valve handle in at the rear of the machine to "TACK".
- b) Remove the spray wand from the storage position in the HOT WELL.
- c) Move the "ASPHALT PUMP" switch to the "SPRAY" position.
- d) Aim the spray wand at the repair area.
- e) Depress the deadman valve handle to open the spray wand hand valve and start spraying the repair area.
- f) Spray the repair area to achieve the desired coverage.
- g) Release the deadman valve handle to close the valve (it is spring-loaded).
- h) Move and hold the "ASPHALT PUMP" switch to the "LOAD, CLEAN" position to return the excess tack oil from the wand back into the tack oil tank.

NOTE: IT IS IMPORTANT TO CLEAN THE TACK OIL SYSTEM AT THE END OF EACH WORKDAY TO PREVENT DAMAGE.

To clean the tack oil spray wand:

- a) Move the "ASPHALT PUMP" switch to the "NEUTRAL" position.
- b) Pull the "TACK\CLEAN" valve handle out at the rear of the machine to the "CLEAN" position.
- c) Move the "ASPHALT PUMP" switch to the "CLEAN/SPRAY" position.
- d) Remove the 3" fill cap from the waste oil tank located on top of the passenger's fender.
- e) Aim the tack oil spray wand into the 3" fill pipe at the rear of the waste oil tank.
- f) Depress the deadman valve handle on the wand and hold it until clear diesel fuel is dispensed.
- g) Move the "ASPHALT PUMP" switch to the "NEUTRAL" position.
- h) Return the tack oil spray wand to the storage position in the HOT WELL.
- i) Push the "TACK\CLEAN" valve handle back into the "TACK" position.

- 9) Dispense asphalt mix material into the repair section to complete the patching process.

TO DISPENSE THE ASPHALT MIX MATERIAL AND COMPLETE THE PATCHING PROCESS, FOLLOW THESE INSTRUCTIONS:

- 1) Pivot the chute and aim it at the area where the asphalt mix material needs to be placed.
- 2) Ensure that the hydraulic doors are closed.
- 3) Move the "CONVEYOR" switch to the "DISPENSE" position.
- 4) Continue dispensing the asphalt mix material until the desired amount has been delivered.
- 5) When finished dispensing, move the "CONVEYOR" switch to the "NEUTRAL" position.

NOTE: IF THE SCREW CONVEYOR STOPS OR BECOMES UNABLE TO TURN DUE TO COMPACTION OR A BLOCKAGE, YOU CAN TRY A FORWARD-REVERSE MOTION TO RESTORE THE DISPENSING MOTION. MOVE THE "CONVEYOR" SWITCH BACK AND FORTH FROM THE "DISPENSE" TO THE "REVERSE" POSITION. KEEP THE MOVEMENT TO THE "REVERSE" POSITION AS SHORT AS POSSIBLE TO AVOID COMPACTION. IF YOUR MACHINE HAS A 2-SPEED CONVEYOR MOTOR, IT SHOULD AUTOMATICALLY SHIFT INTO "LOW TORQUE/HIGH SPEED" ONCE THE MATERIAL STARTS TO MOVE. IF THE CONVEYOR FAILS TO DISPENSE MATERIAL, IT SHOULD BE SERVICED AND CHECKED.

- 10) Prepare the asphalt mix material for compaction by leveling and/or raking it to the desired height above the existing street level using an asphalt rake.
- 11) Complete the compaction operation using either the hydraulic breaker with the 6" square tamping shoe, the gasoline-driven vibratory plate compactor, or the gasoline-driven vibratory roller compactor.

Note: Refer to the specific brochures provided with the vibratory plate compactor or vibratory roller compactor for operating instructions.

- 12) Before moving to the next repair site, ensure the following:
 - All tools are picked up and securely fastened down or stored in their proper place.
 - All dust caps (for hydraulic tools) are in place.
 - The power take-off is disengaged.
 - Tool and control compartment doors are securely fastened.

CAUTION: NEVER STAND INSIDE THE HOPPER OR PERFORM ANY WORK IN THE HOPPER WHILE ANY PORTION OF THE MACHINE IS OPERATING. FAILURE TO SHUT DOWN THE ENTIRE MACHINE BEFORE SERVICING MAY RESULT IN BODILY INJURY OR DEATH.

To utilize the anti-bridge bar:

- 1) Ensure that the hydraulic doors are closed.
- 2) Move the "ANTI-BRIDGE BAR" switch momentarily to "FORWARD" and then to "REVERSE" until the Anti-Bridge Bar has moved 1/4 turn in both directions. This motion will cause any bridged asphalt mix to fall or shift down into the screw conveyor.
- 3) The Anti-Bridge Bar is designed to rock back and forth; it should not be turned continuously in either direction.

Follow these instructions carefully to ensure safe and effective operation of the Thermo-Lay machine during the patching process.

Caution: Never stand inside the hopper or perform any work in the hopper with any portion of the machine operating. Failure to shut down the entire machine prior to servicing may cause bodily injury or death.

To operate the hydraulic doors:

- 1) Move the "DOOR" switch to either the "OPEN" or "CLOSED" position as required. Note that the doors move slowly and should not slam open or closed. These doors are not designed to level the asphalt mix inside the hopper; leveling should be done by hand.
- 2) The hydraulic pressure setting on the doors prevents them from being damaged if they become jammed against something.
- 3) Minimizing any build-up around the door cylinders inside the hopper is important. Although the cylinders are guarded against asphalt being dumped on them, some asphalt mix may adhere to them. If this build-up is not kept to a minimum, it can cause damage to the cylinder hoses and hinder the operation of the doors.

WARNING: ENSURE NO PERSONNEL IS IN THE HOPPER BEFORE CLOSING THE DOORS TO PREVENT SEVERE BODILY INJURY.

To operate the hydraulic lift for the vibratory roller:

- 1) Before operating the lift, ensure no feet or obstructions are underneath it.
- 2) Push in the large red "DOWN" button located near the lift and hold it until the lift reaches the desired ground level. This lowers the lift.
- 3) To raise the lift, make sure there are no personnel near the lift. Hold in the green "UP" button until the lift reaches the fully upright locked position and the amber strobe light stops flashing.
- 4) The lift is not designed to raise and lower the entire truck and has a pressure relief setting to prevent such attempts.

FOLLOW THESE INSTRUCTIONS CAREFULLY TO SAFELY OPERATE THE HYDRAULIC DOORS AND HYDRAULIC LIFT ON THE THERMO-LAY MACHINE.

To manually override the hydraulics when the switches fail (without the sanding option), follow these steps:

- 1) In case of a switch failure, the hydraulic functions of the machine can be manually operated. Each control valve section is labeled to indicate which bank operates which function. The following functions can be manually overridden spraying the tack oil and cleaning the tack oil system, dispensing asphalt mix, opening the doors, and raising the plate/roller lift.
- 2) To manually operate these functions, you will need two small Phillips screwdrivers, approximately 1/8" in diameter. Each function requires the operation of a common valve along with the corresponding function valve. Therefore, you need to operate the common valve bank section along with the desired function valve.
- 3) Stand on the passenger side of the machine, facing toward the rear. Insert one Phillips screwdriver into the center of the valve section marked "TOOLS." While holding in on this valve, insert the other Phillips screwdriver into the control valve bank center.

It's important to exercise caution when manually overriding the hydraulics. If you are unsure or uncomfortable performing these steps, it's recommended to seek professional assistance or consult the machine's manufacturer for further guidance.

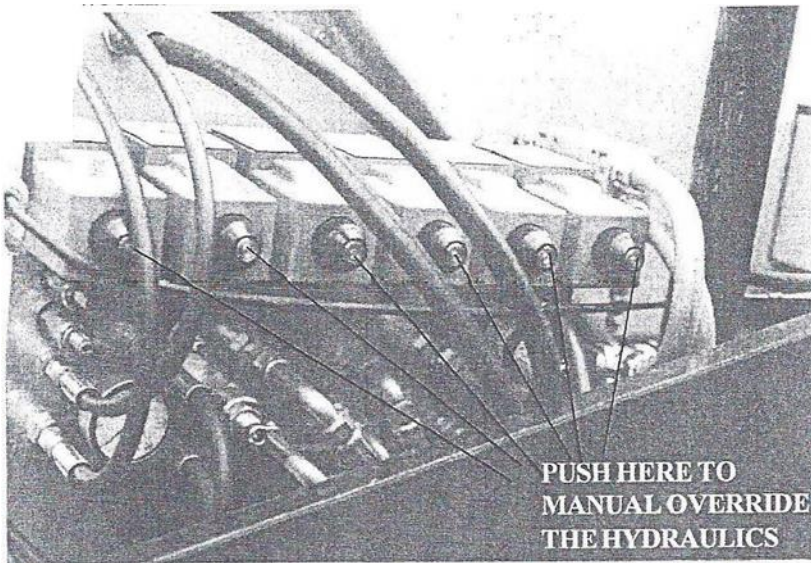

To manually override the hydraulics when the switches fail (with the sanding option), follow these steps:

- 1) In the event of a failure of the function switches, the hydraulic functions of the machine can be manually operated.
- 2) To manually operate these functions, you will need a 5/16" open-end wrench. Each valve section has a small 5/16" hex located under the coil end, which can be manually rotated to move the interior spool.
- 3) Stand on the passenger side of the machine, facing toward the rear. Attach the 5/16" end wrench to the hex part of the desired valve section. This will operate the selected function. Moving the wrench in one direction will provide forward control, while moving it in the opposite direction will provide reverse control.

Note: The order in which the solenoid valves are positioned is as follows, starting from the inboard valve and working outward to the curbside: hydraulic tools, asphalt pump, screw conveyor, anti-bridge bar, hydraulic doors, hydraulic lift, and arrow board.

Exercise caution when manually overriding the hydraulics and ensure that you are familiar with the specific functions and their corresponding valves. If you are unsure or uncomfortable taking these steps, it is advisable to seek professional assistance or consult the machine's manufacturer for further guidance.

The asphalt tack oil tank, located under the right side of the main Thermo-Lay unit, is designed specifically for storing, circulating, and dispensing cut-back or emulsion tack oil. It is important to note that this tank is NOT intended for storing, transporting, or dispensing asphalt cement.

The tank is capable of accommodating various types of tack oil, including grades RS-1, RS-2, SRS-1, CRS-2, SS-1, SS-1H, CSS-1, CSS-1H, MS-1, HFMS-1, CMS-2H, HFMS-2, HFMS-2H, MC-70, MC-250, MC-800, RC-70, RC-250, RC-800, SC-70, SC-250, and SC-800.

Temperature control for the oil in the tack oil tank is achieved by circulating heated transfer oil through a heat pipe integrated into the tank. The amount of heat transfer oil flowing through the heat pipe can be adjusted using a valve handle located at the rear of the machine, labeled "HOTTER" and "COLDER." Increasing the valve handle position towards "HOTTER" allows more heat transfer oil to circulate, resulting in higher temperatures. When the main body is connected to a 240-volt power source to operate the 9 KW Electric Heater, the heat transfer oil transfers heat to the tack oil, maintaining its temperature. It is important to note that emulsion oil should not be heated above 120 degrees Fahrenheit. The temperature of the tack oil can be monitored using the thermometer located at the right rear of the machine.

The tack oil tank also features a built-in circulating feature. When the machine has hydraulic pressure, pushing the TACK/CLEAN valve "IN" and setting the "PUMP" switch to the "SPRAY, CLEAN" position activates the pump to circulate and agitate the oil within the tank. When the spray wand valve is opened, the pump

dispenses the oil through the wand and nozzle. Whenever the wand valve is closed and the pump is operational, the pump will automatically circulate the tack oil. It is important to avoid excessive circulation or mixing of emulsion oil, as it can cause coagulation due to demagnetizing the electrically charged particles in the oil. Therefore, it is not recommended to operate the pump continuously for extended periods when the emulsion is stored in the tank. Additionally, allowing the oil to sit still for prolonged periods can cause it to thicken. More information on emulsified oils can be obtained from the Asphalt Institute.

Coagulation of emulsion oil can also occur due to dilution by water. The Asphalt Institute suggests a quality measure where an emulsion sample, after adding and stirring distilled water, is examined for coagulation of the asphalt droplets in the emulsion after standing for two hours. To avoid severe coagulation problems, it is recommended to test the emulsion oil for dilution upon initial use in the machine. Further information is available from the Asphalt Institute (#MS-19).

At the end of each workday, it is recommended that operators clean the system following the provided cleaning instructions. This ensures that the emulsion oil does not set up in the pump or its piping during non-operation hours. Excessive amounts of emulsion oil should also be avoided in the tank. It is advisable to store only as much oil as can be dispensed within two or three work shifts to prevent coagulation issues.

SAFETY RECOMMENDATIONS

The following safety recommendations are provided for the safe operation and use of the Thermo-Lay machine:

1. It is the responsibility of the user to ensure that the machine is equipped with proper backup devices, barricades, flashing lights, or any other required safety equipment according to OSHA, local, state, federal, or other safety regulations. Additional safety items beyond those provided with the Thermo-Lay machine should be used. Northwest Manufacturing and Distribution, Inc. cannot be held responsible for any damage to individuals or property resulting from the lack of proper safety equipment not supplied with the unit.
2. Follow the correct procedures for operating the Thermo-Lay machine as outlined in the provided operating instructions. Adhere to proper maintenance and operational procedures and conduct regular inspections to ensure safe operation under prevailing conditions.
3. Exercise caution to prevent contact between the automatic propane burner torch at the rear of the truck and flammable materials or personnel. Turn off the burner when in or near fuel-loading areas containing gasoline, turbine fuel, diesel fuel, or any other volatile or flammable substances. The burner will automatically reignite when additional temperature and heat are required.
4. Ensure that the thermostat setting does not exceed the flash point setting for the tack oil stored in the Thermo-Lay's tack oil tank. The recommended flash point temperature can be obtained from the oil supplier. Exceeding the flash point temperature may result in spontaneous ignition of the oil, causing serious damage to the machine and posing a risk of injury to personnel.
5. Never operate the machine while any personnel are attempting to fix, clean, service, or repair any part of the machine. It is the operator's responsibility to ensure that the machine is serviced without the machine operating.
6. Avoid any water contact with the tack oil inside the 120-gallon radiant heat transfer oil reservoir. Even a small amount of water can cause the heat transfer oil to erupt from the machine when heated, potentially leading to ignition at the propane burner.
7. When using the hydraulic doors, verify that the top area is clear of personnel before opening or closing them.
8. Use caution when lowering the VIBRATORY LIFT to prevent feet or other materials from being underneath the lift platform.
9. Exercise caution while the machine is in operation. Hydraulic pumps and motors rotate at high speeds and operate under high hydraulic pressure. Keep hands clear of rotating machinery both in the front and rear of the machine.
10. The propane torch should only be used for heating the repair area and should not be used for any other purpose. The torch should be ignited using an external source, such as a striker, and not by using the main propane burner.
11. Engage the hydraulic breaker only when gripping it tightly with both hands and ensuring that the tamping shoe or asphalt cutting spade is against the ground.
12. Familiarize all operators with the warning labels on the machine.
13. Before attempting any repairs on the machine or entering the hopper, remove the truck engine keys and keep them in your personal possession. Failure to do so may result in bodily injury, amputation, or death.

MAINTENANCE INSTRUCTIONS

The following maintenance tasks are required for the Thermo-Lay machine:

1. Check hydraulic oil level DAILY PRIOR TO EACH USE: Verify that the hydraulic oil is at the recommended level.
2. Check radiant oil level DAILY PRIOR TO EACH USE: Ensure that the radiant oil in the heat transfer system is at the proper level.
3. Check asphalt oil level DAILY PRIOR TO EACH USE: Verify the level of asphalt oil in the tank.
4. Check diesel fuel level DAILY PRIOR TO EACH USE: Check the level of diesel fuel in the machine's fuel tank.
5. Check propane fuel level DAILY PRIOR TO EACH USE: Ensure that there is an adequate amount of propane fuel available.
6. Replace the hydraulic filter WHEN THE HYDRAULIC OIL IS CHANGED to maintain proper filtration of the hydraulic system.
7. Change hydraulic oil: Replace the hydraulic oil with fresh oil to maintain optimal performance.
 - Heavy usage – every 12 months
 - Medium usage – every 18 months
 - Light usage – every 24 months
8. Asphalt pump maintenance: Perform maintenance tasks specific to the asphalt pump, as outlined in the Viking TS000 and TS312 bulletins.
9. Grease all bearings MONTHLY: Apply grease to all bearings to ensure smooth operation and reduce friction.
10. Inspect the screw conveyor for any signs of wear, damage, or misalignment EACH TIME ASPHALT HOPPER IS EMPTY.
11. Check flight thickness at the outer edge of flights WEEKLY: Measure the thickness of the flights at the outer edge to ensure they meet specifications.
12. Check the screw conveyor for bent or worn bolts on the coupling: Inspect the bolts on the coupling of the screw conveyor for any bending or wear WEEKLY.
13. Ensure that the bolt holes on the screw conveyor are not widening, which could indicate excessive wear WEEKLY.
14. Check screw conveyor diameter: Verify that the screw conveyor has the correct diameter as specified in the manual WEEKLY.
15. Check screw conveyor set screws and tighten them if necessary, WEEKLY.
16. Examine all nuts and bolts on the machine and tighten any that may have come loose DAILY BEFORE EACH USE.
17. Check for loose hydraulic fittings: Inspect all hydraulic fittings and connections for any signs of looseness and tighten if needed DAILY PRIOR TO USE.
18. Calibrate the thermostat to ensure accurate temperature control MONTHLY; consult the Fenwell 400 Bulletin.

19. Verify that the pressure relief valve on the control valve is functioning correctly ANNUALLY, Set at 2000psi, consult calibration of control valve in this section.
20. Clean asphalt system DAILY.
21. Disassemble and clean the asphalt spray wand valve by dismantling and scrubbing with a cleaning solvent and reassembling it WEEKLY OR AS NEEDED to maintain proper functionality.
22. Sample the heat transfer oil at specific intervals: Take oil samples from the heat transfer system at designated intervals (e.g., 50, 100, 500, 1000 hours) for analysis, not to exceed more than 4% acid.
23. Clean the complete unit: Perform a comprehensive cleaning of the entire machine to remove dirt, grime, and other contaminants DAILY.
24. Clean the buildup under the screw conveyor: Remove any accumulated material or debris under the screw conveyor WEEKLY, MUST BE CLEANED.
25. Check all electrical connections MONTHLY.
26. Clean hydraulic couplings: Remove any dirt or debris from the hydraulic couplings WEEKLY OR AS NEEDED. Always keep the couplings as clean as possible. Dirt and grit passed through the couplings can cause serious damage to hydraulic pumps, etc.

TROUBLESHOOTING GUIDE

AUTOMATIC PROPANE BURNER SYSTEM

SYMPTOM POSSIBLE SOLUTIONS

- (1) Unit does not spark - Check if the probe SPARK gap is set to the proper gap (1/8"). Adjust if needed. - Ensure that the thermostat setting is not below the actual oil temperature. - Check the position of the "PUMP" switch. If it is in the "SPRAY" position, the burner may not ignite while the "PIJVVIP" switch is in this position. - Replace the spark board if it is inoperable. - Consult the factory if the problem persists.
- (2) Unit sparks but does not light - Check all valves to ensure they are open. - Inspect the solenoid valves to ensure proper opening and closing. - Check for debris in the orifice of the burner torch that may be causing a blockage. - Examine the orifice first (left) solenoid valve for any debris. - If the issue persists, consult the factory.
- (3) Unit lights on low pressure but won't reach high pressure - Check for debris in the orifice of the burner torch that may be causing a blockage. - Inspect the orifice first (left) solenoid valve for debris. - Make sure that the orifice's first (left) valve opens within 10 seconds from the start to ignition. If not, replace the solenoid top or the 10-second relay. - Verify the output of the regulator is at 10 p.s.i. - If the problem continues, consult the factory.
- (4) Unit lights, goes to high pressure - If the probe is not staying lit, re-adjust its position so that approximately 1" of the probes is in front of the flame. - Check if the probe is in the flame. - Verify that the probe is transmitting a minimum of 50 M.A. V.D.C. when hot. If not, replace the probe. - If further assistance is required, consult the factory.
- (5) Any other problems - It is recommended to consult the factory for assistance in diagnosing and resolving any other issues related to the automatic propane burner system.

PLEASE REFER TO THE FLOW CHART IN THIS SECTION TO UNDERSTAND THE VARIOUS SCENARIOS THAT MAY OCCUR WHEN THE BOARD SHUTS DOWN. IT'S IMPORTANT TO NOTE THAT THERE ARE TWO WAYS IN WHICH THE BOARD MAY SHUT DOWN - ONE WHERE THERE IS A 7-SECOND DELAY BETWEEN THE TIME THE FLAME STOPS AND THE "RED" LIGHT FLASHES THREE TIMES, INDICATING A LOSS OF PROPANE, AND THE OTHER WHERE THE FLAME IMMEDIATELY STOPS AND THE LIGHT INSTANTLY FLASHES THREE TIMES, INDICATING THAT THE FLAME SENSOR SYSTEM IS EITHER GROUNDED OR BROKEN. THE FLOW CHART SHOULD PROVIDE A CLEAR UNDERSTANDING OF EVERY POSSIBILITY ASSOCIATED WITH THIS SYSTEM.

APR 19 1954

APR 19 1954

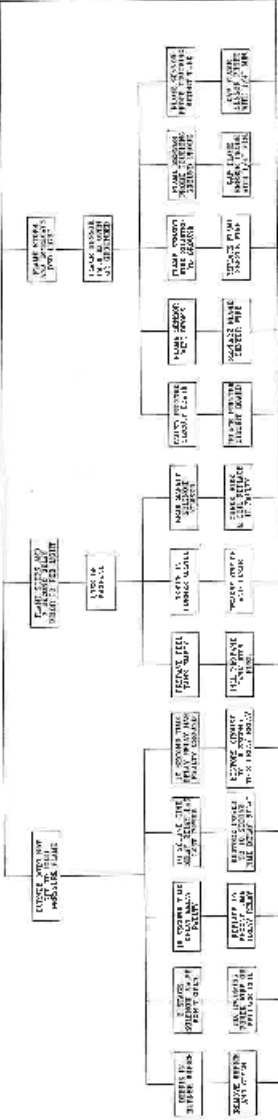

U.S. ARMY

PATCHING SYSTEM

SYMPTOM POSSIBLE REMEDY

- (1) Hydraulic tools won't operate - Ensure that the Power Take-Off (PTO) is disengaged. - Check the "TOOL" switch position. Ensure it is in the proper position for operating hydraulic tools. - Make sure the engine "KEY" switch is in the "ON" position. - If the issue persists, consult the factory for further assistance.
- (2) Asphalt Spray Wand won't spray - Check if the asphalt pump is engaged and in the spray position. - Ensure the Deadman hand valve on the wand is open. - Clean the spray wand if it is plugged. - If the problem continues, consult the factory.
- (3) Electric Heater will not operate - Verify if the plug is properly connected, ensuring a twist and lock connection. - Check if the 50 AMP breaker is in the "ON" position. - Ensure the temperature setting is correct, higher than the oil temperature. - Replace the "POWER ON" light bulb if it is burned out. - If the electric heater still does not operate, consult the factory.
- (4) Hydraulic Breaker won't operate - Make sure the Power Take-Off (PTO) is engaged. - Check that the hydraulic hose couplers are properly connected. - Ensure the "TOOL" switch is in the "OPERATE" position. - Depress the Breaker handle valve to operate. - Refer to the hydraulic Breaker operating manual for further instructions. - If needed, consult the factory.
- (5) Vibratory Plate or Roller won't operate - Ensure that the Power Take-Off (PTO) is engaged. - Consult the specific Vibratory Plate or Roller information for troubleshooting steps. - If assistance is required, consult the factory.
- (6) Asphalt Tack Oil Pumping problems - Verify that the Tack Oil is hot enough for pumping. - Clean the pump if there are any blockages. - Refer to Bulletin TS000 or TS 312 in the Equipment Bulletin Section for additional guidance. - If the issue persists, consult the factory.
- (7) Hydraulic motors & hydraulic system - For any problems related to hydraulic motors or the hydraulic system, it is recommended to consult the factory for assistance.
- (8) Hydraulic couplings cannot be connected - Release trapped pressure in the Breaker by unscrewing the couplers. - Move the "TOOL" switch back to neutral to release the trapped pressure in the system and allow it to bleed down. - If further support is needed, consult the factory.
- (9) Hydraulic Breaker heats up when used - Slow engine RPM down to 10 GPM flow at flow meter. - Consult the factory for further assistance.
- (10) Control valve "squeals" - Check the pressure relief setting (2150 psi). - Consult the factory for further guidance.
- (11) Screw Conveyor will not turn - Ensure that the hydraulic doors are closed. - Engage the Power Take-Off (PTO). - Move the "CONVEYOR" switch to the "Dispense" position. - If the problem persists, consult the factory.
- (12) Screw Conveyor turns but does not dispense material - Material may be "packed" around the Screw Conveyor. Reverse the Screw Conveyor momentarily and then return it to the "Dispense" position. - If material is bridged, use an Anti-Bridge Bar. - Consult the factory for additional assistance.
- (13) Hydraulic oil becomes "HOT" - Consult the factory immediately. Do not continue to operate the equipment.

Note: Most problems associated with the patching operation are operator errors or lack of operator training. After reading the manual, consulting the factory before attempting any repairs is recommended to save time, energy, and money. The factory can provide further guidance and support.

OTHER ISSUES

If you encounter any other problems with the unit that are not covered by the troubleshooting steps provided, it is recommended to consult the factory for further assistance. The factory will have in-depth knowledge of the Thermo-Lay machine, its components, and specific troubleshooting procedures. They will be able to provide you with the most accurate and reliable guidance to address any unique or complex issues you may be experiencing. Contact the factory directly and provide them with detailed information about your problem for prompt and effective support.

DRAWING PART NUMBER IDENTIFICATION - MAIN BODY

1. Main Body
2. Asphalt Mix Hopper (Bin)
3. Asphalt Tack Oil Tank (reservoir)
4. Radiant Heat Transfer Oil Tank Reservoir
5. Propane Burner Retort Tube
6. Propane Burner Retort Tube Exhaust Stack
7. 350,000 BTU Propane Burner
8. 34 Gallon Horizontal Propane Tank
9. 10 lb. Vapor Propane Regulator
10. Propane Bottle Shut-off Valve
11. Orifice Propane Solenoid for the Main Burner
12. Asphalt Tack Oil Cleaning Valve
13. 6" X 2/3 Pitch (4" spaced flights) Screw Conveyor (auger)
14. Rear Screw Conveyor Support Bracket
15. Screw Conveyor Directional Control Switch
16. Anti-Bridge Bar Control Switch
17. Asphalt Tack Oil Pump Control Switch
18. Hydraulic Power Tool (breaker) Switch
19. Hydraulic Door Control Switch
20. Propane Safety Shut-off Solenoid Valve for the Main Burner
21. Asphalt Tack Oil Fill Spout
22. Radiant Heat Transfer Oil Fill Spout
23. Hydraulic Oil Tank
24. Hydraulic Suction Valve & Strainer
25. Hydraulic Discharge Filter
26. 6 Bank Open Center Hydraulic Solenoid Control Valve
27. Screw Conveyor Hydraulic Motor
28. Front Screw Conveyor Motor Bracket
29. Tack Oil Pump Hydraulic Motor
30. Tack Oil Pump Pipe & Hose
31. Radiant Heat Transfer Oil Temperature Thermostat
32. Asphalt Tack Oil Pump
33. Anti-Bridge Hydraulic Motor
34. Front Anti-Bridge Motor Bracket
35. Asphalt Tack Oil Spray Wand
36. 4 Bolt 1 1/2" Flange Bearing
37. Radiant Heat Transfer Oil Thermostat Probe
38. Radiant Heat Transfer Oil Thermostat Probe Box
39. Rear Tail Light (2 required)
40. Electrical Control Box (2 required)
41. 250,000 BTU Hand Propane Torch
42. Radiant Heat Transfer Oil Digital Temperature Gauge
43. Front Screw Conveyor (auger) Drive Shaft
44. Mud Flaps (2 required)
45. Hydraulic Breaker Tool Holder
46. Step Fenders (left & right)
47. Screw Conveyor (auger) Trough
48. Diesel Spray Tank
49. Hydraulic Tank Sight Gauge & Thermometer
50. Hydraulic Tool Pressure Flow Meter
51. Hydraulic Tool Pressure Return Lines
52. Hydraulic Door Cylinder
53. Hydraulic Lift Platform
54. Hydraulic Lift Platform Cylinder

55. Rear Radiant Heat Transfer Oil Heat Flow Control Valve
56. Front Radiant Heat Transfer Oil Heat Flow Control Valve
57. Hydraulic Lift Control Box
58. Radiant Heat Transfer Oil Dip Stick Level Indicator
59. Asphalt Tack Oil Dip Stick Level Indicator
60. Asphalt Tack Oil Temperature Gauge
61. Hydraulic Control Panel & Switches
62. Hydraulic Doors
63. Remote Throttle Cable
64. Asphalt Tack Oil Spray Wand Deadman Valve
65. Asphalt Mix Delivery Chute Assembly
66. 240 Volt 9 K.W. Electric Heater
67. Hydraulic Lift Platform Safety Check Valve
68. Hand Propane Torch Manual Shut-off Valve
69. Diesel Fuel Hose Reel
70. Anti-Bridge Bar Section (2 required)
71. Hydraulic Tool Twin Hose Reel
72. Asphalt Tack Oil Hose Reel
73. 10 Gallon Waste Oil Tank (built into the right fender)
74. Asphalt Tack Oil Check Valve
75. Hydraulic Breaker (72# standard)
76. Hand Propane Torch Safety Shut-off Solenoid Valve
77. Sanding Chute Assembly
78. Sanding Chute Motor
79. Sanding Chute Hoses
80. Anti-Bridge Bar Center Support Shaft
81. Anti-Bridge Bar Center Support Bearing
82. Asphalt Tack Oil Motor Coupling
83. Diesel Fuel Hand Spray Wand
84. Screw Conveyor (auger) Motor Coupling
85. Anti-Bridge Bar Motor Coupling
86. Anti-Bridge Bar Front Drive Shaft
87. Waste Oil Tank Fill
88. Waste Oil Tank Drain for the Asphalt Tack Oil Spray Wand
89. Asphalt Tack Oil Spray Wand Nozzle
90. Trash (spoils) Bins
91. Hydraulic Directional Arrow Board Assembly
92. Hydraulic Directional Arrow Board Lens Hood (20 required)
93. Hydraulic Directional Arrow Board Display Section (4 required)
94. Hydraulic Arrow Board Cylinder
95. Strobe Light
96. Propane Tank Remote Gauge
97. Propane Tank Remote Fill Box Assembly
98. Propane Tank Remote Fill Adapter
99. Diesel Pump
100. Hydraulic Door Clearance Light
101. Hydraulic Door Hinge Rubber
102. Hydraulic Door Seal
103. Hydraulic Door Hinge Assembly
104. Hydraulic Door Guide Roller Assembly
105. Clearance Light (red-rear & amber-front)
106. Screw Conveyor (auger) Rear Shaft
107. Diesel Tank Fill Spout
108. Propane Safety Shut Down Light
109. Radiant Heat Transfer Oil Fill Vent
110. Asphalt Tack Oil Fill Vent

111. Anti-Bridge Bar Rear Shaft

Please note that the descriptions provided here are based on the given part numbers and may vary depending on the specific equipment or manufacturer. It is always recommended to consult the equipment manual or the manufacturer for accurate and up-to-date information on part numbers and identification.

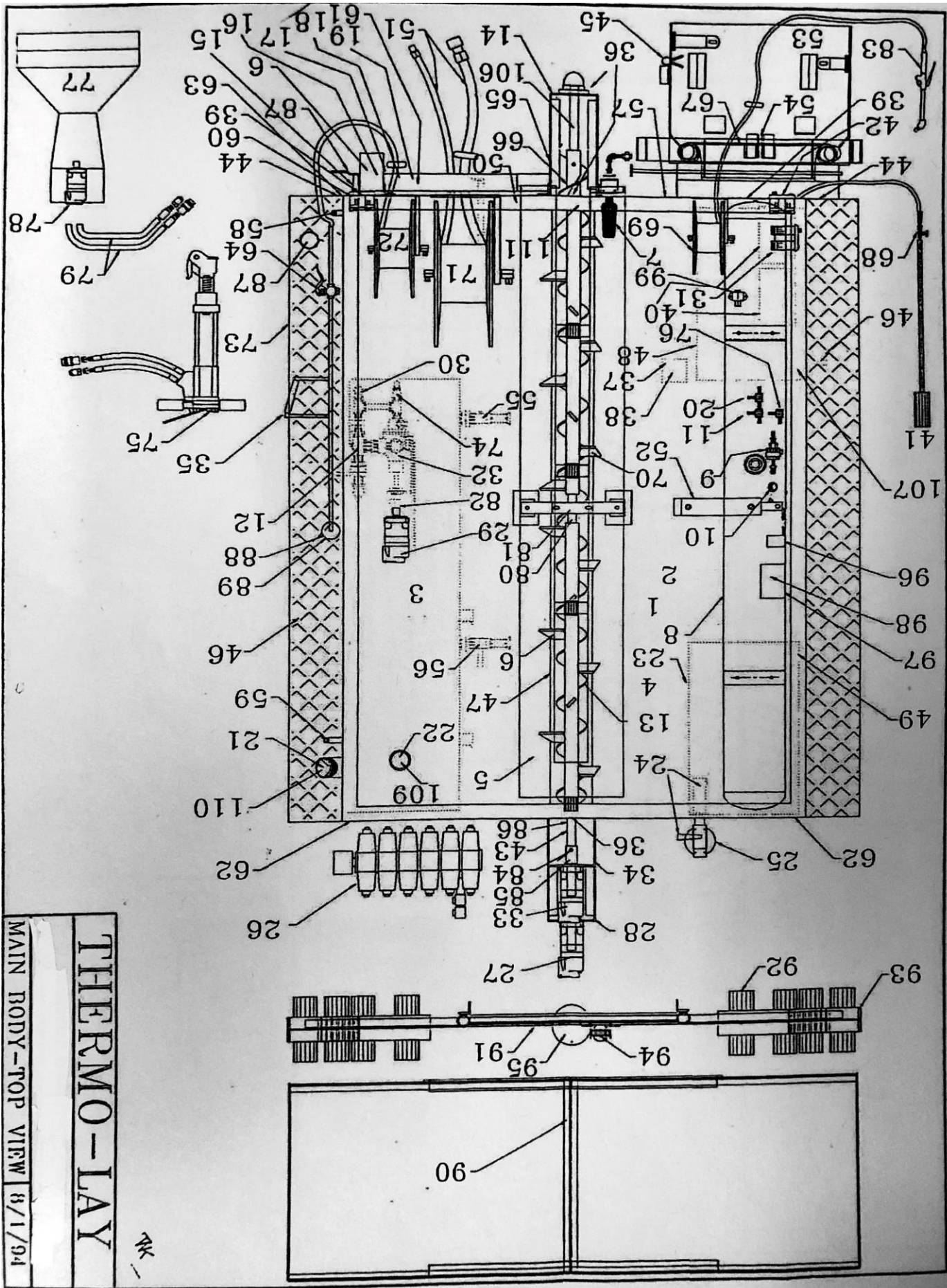

THERMO-LAY

MAIN BODY - TOP VIEW 8/1/94

2

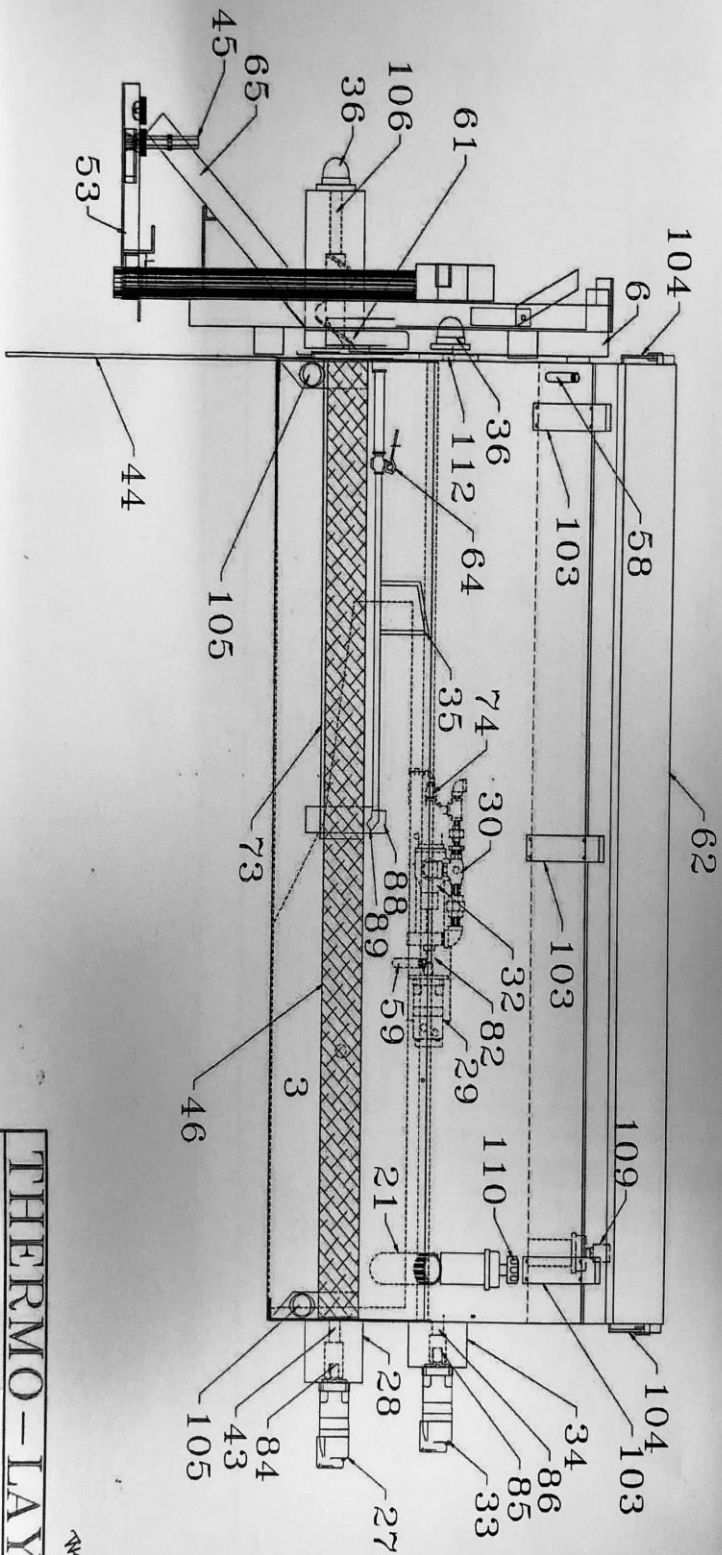

THERMO-LAY

MAIN BODY-RIGHT VIEW 8/1/94

AK

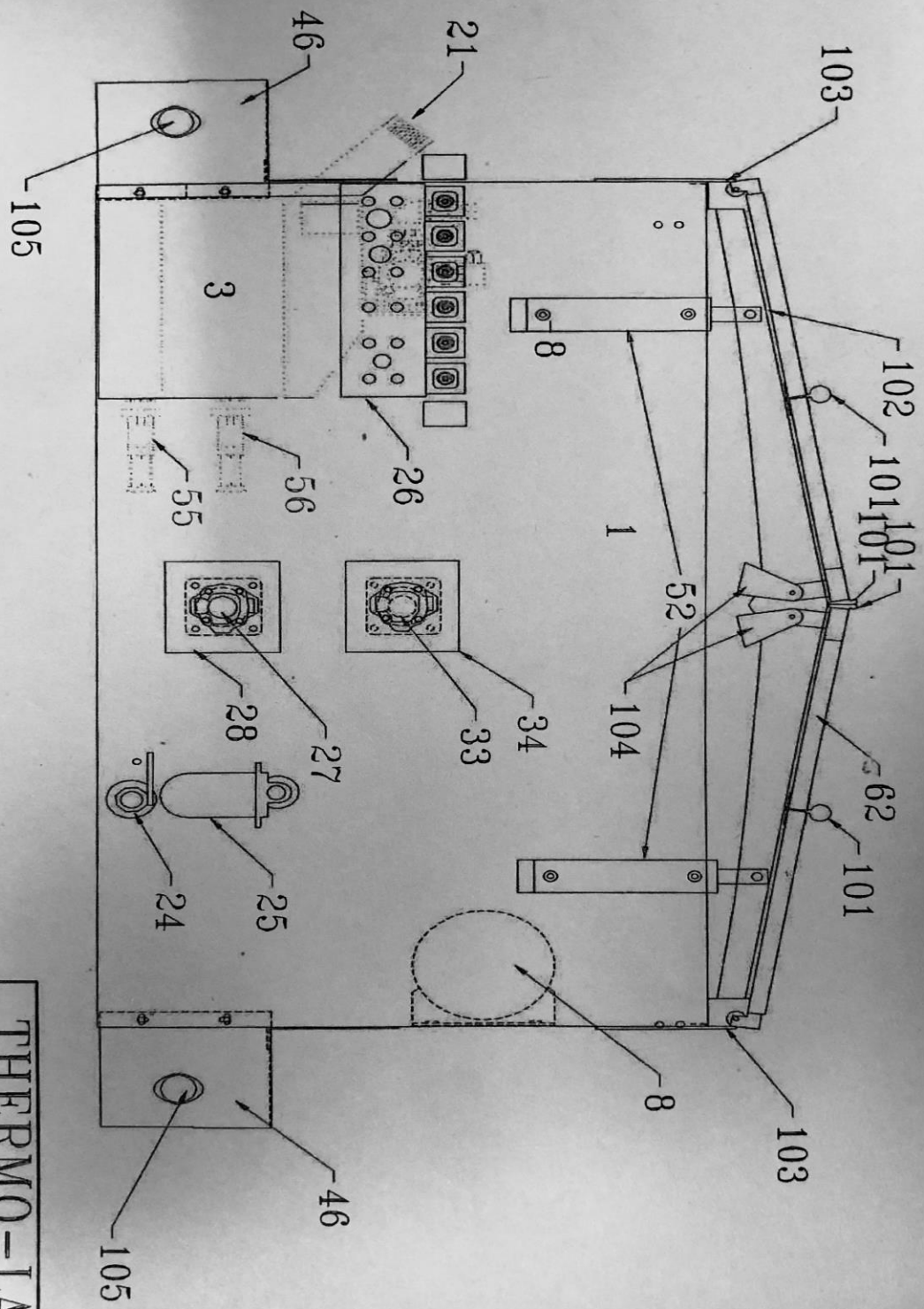

THERMO-LAY

MAIN BODY-FRONT VIEW 8/1/94

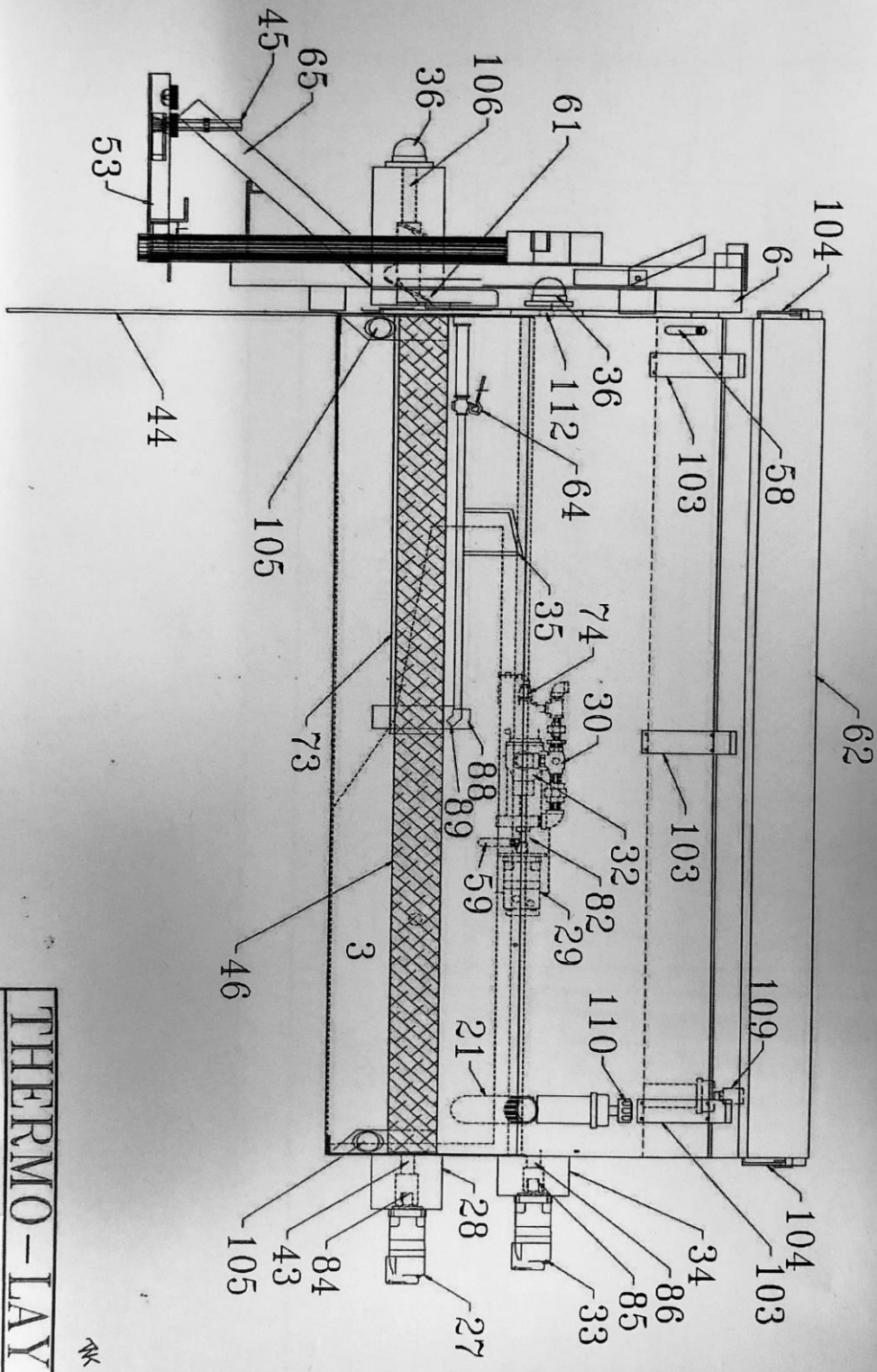

THERMO-LAY

MAIN BODY-RIGHT VIEW 8/1/94

AK

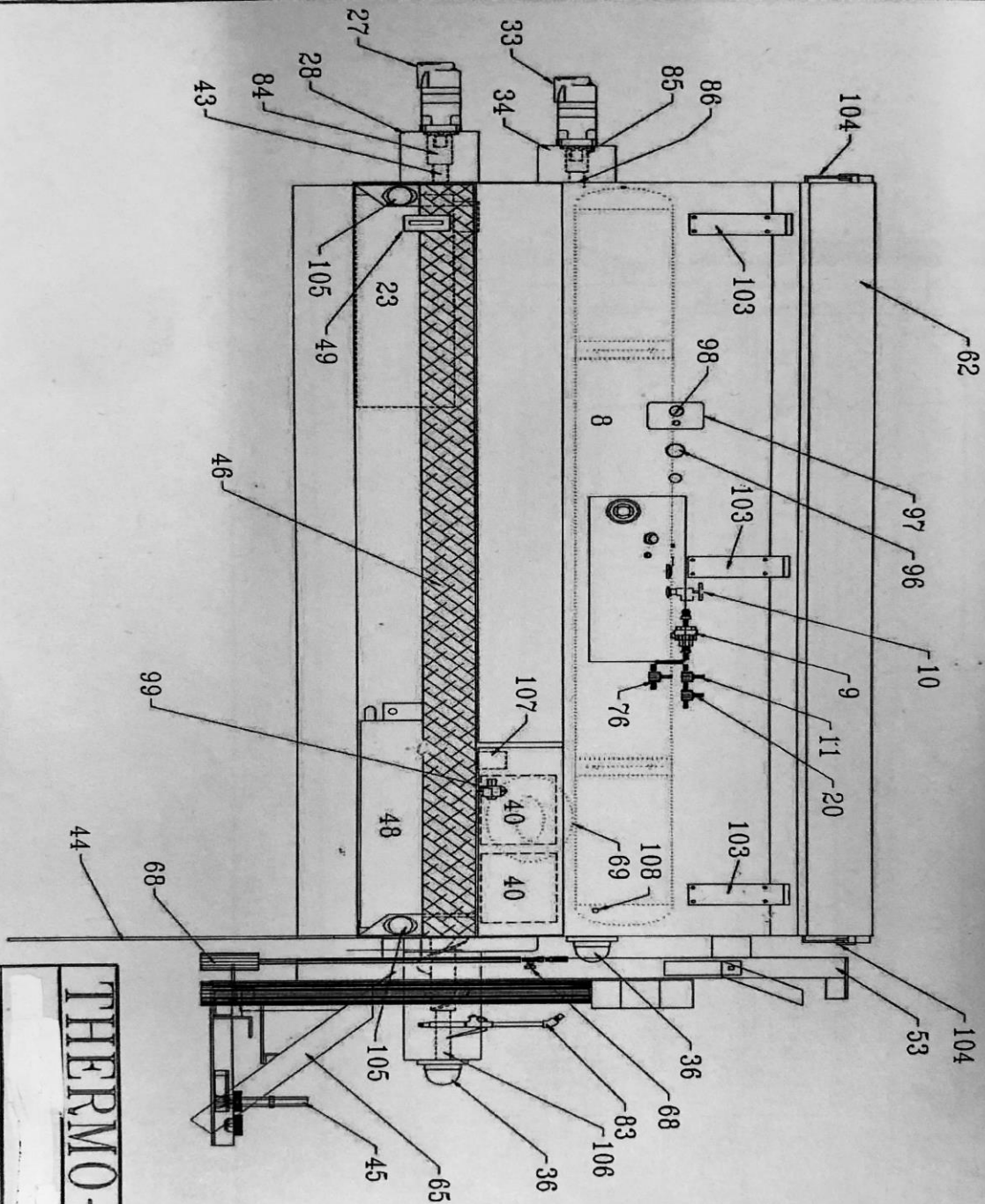

THERMO-LAY

MAIN BODY-LEFT VIEW 8/1/94

W

DRAWING PART NUMBER LIST FOR MAIN BODY DRAWINGS

ITEM	DESCRIPTION	PART NUMBER
1.	Main Body	NMD-425-120MB
2.	Asphalt Mix Hopper Bin	Included in Main Body
3.	Asphalt Tack Oil Tank	NMD-TOT-120
4.	Radiant Heat Transfer Oil Reservoir	Included in Main Body
5.	Propane Burner Retort Tube	NMD-RET-U
6.	Propane Burner Retort Tube Exhaust Stack	NMD-NEST-2
7.	350,000 BTU Propane Burner	LBW-L-BRTHA-350
8.	34 Gallon Horizontal Propane Tank	MAN-676474-34
9.	10# Vapor Propane Regulator	R300/21
10.	Propane Bottle Shut-off Valve	MAN-MULTI
11.	Orifice Propane Solenoid Valve	LPG-7008B-D-69
12.	Asphalt Tack Oil Cleaning 3-Way Valve	NMD-TOT-CLN-VLV
13.	6" X 2/3 Pitch Screw Conveyor	NMD-LPSC-4-9/10
14.	Rear Screw Conveyor Support Bracket	NMD-SC-RER-SUP-BRKT
15.	Screw Conveyor Control Switch	2TL1-5-MS24524-3 I
16.	Anti-Bridge Bar Control Switch	2TL1-7-MS24524-27
17.	Asphalt Tack Oil Pump Control Switch	2TL1-5-MS24524-3 I
18.	Hydraulic Power Tool Control Switch	2TL1-5-MS24524-3 I
19.	Hydraulic Door Control Switch	2TL1-7-MS24524-27
20.	Propane Safety Shut-Off Solenoid Valve	LPG-7008B
21.	Asphalt Tack Oil Fill Spout	Included in Tack Tank
22.	Radiant Heat Transfer Oil Fill Spout	Included in Main Body
23.	Hydraulic Oil Tank	NMD-HYD-TNK-30
24.	Hydraulic Suction Valve & Strainer	TM-25-RV5
25.	Hydraulic Discharge Filter	FSP-2121-EDNN
26.	6-Bank Hydraulic Control Valve	DRVT-6-12V
27.	Screw Conveyor Motor	CHAR-LYNN-109-1106
28.	Front Screw Conveyor Bracket	NMD-SC-MTR-BRKT
29.	Asphalt Tack Oil Pump Motor	CHAR-LYNN-104-001
30.	Asphalt Tack Oil Pump Pipe & Hose	NMD-TOPH-12
31.	Radiant Heat Transfer Oil Thermostat	NMD-ANT-ITC-151-R
32.	Asphalt Tack Oil Pump	HL432B
33.	Anti-Bridge Bar Motor	CHAR-LYNN-104-1143
34.	Anti-Bridge Bar Motor Bracket	NMD-ABB-FRNT-MTR-BRK
35.	Asphalt Tack Oil Spray Wand	NMD-TOT-SPRY-WND
36.	4-Bolt Bearing (Screw Conveyor, Anti-Bridge Bar)	FC-425-X-1.5
37.	Radiant Heat Transfer Oil Thermostat Probe	NMD-EM-G706J
38.	Thermostat Probe Box	NMD-HOF-4X4X4
39.	Rear Taillight	77VAG-02122
40.	Electrical Control Box	NMD-HOF-10X8X6
41.	250,000 BTU Hand Torch	VT-2.5X30
42.	Radiant Heat Transfer Oil Temperature Gauge	NMD-ANT-TTD-1510060
43.	Front Screw Conveyor Drive Shaft	NMD-SC-FRT-DRV-9.5
44.	Mud Flaps (Each)	NMD-SYM-GRAY
45.	Hydraulic Breaker Holder	Included on Hydraulic Lift Platform
46.	Step Fenders (Each)	NMD-RHF & NMD-LHF

ITEM	DESCRIPTION	PART NUMBER
47.	Screw Conveyor Trough	Included in Main Body
48.	Diesel Spray Tank	NMD-18G-DFT
49.	Hydraulic Tank Sight Gauge	FSA 76-1.1/fl 2
50.	Hydraulic Tool Flow Meter	HEDLND-686-213
51.	Hydraulic Tool Pressure Return Lines	NMD-HYD-PRS-FL-HS NMD-HYD-RTN-FL-HS
52.	Hydraulic Door Cylinder	PMC-5408
53.	Hydraulic Lift Platform	NMD-HCLG-24
54.	Hydraulic Lift Platform Cylinder	SAE-9024
55.	Rear Radiant Oil Transfer Valve	NMD-TOT-RDNT-VLV
56.	Front Radiant Oil Transfer Valve	NMD-TOT-RDNT-VLV
57.	Hydraulic Lift Control Box	NMD-HYD-LFT-CNTRL-BX
58.	Radiant Oil Dipstick Level Indicator	NMD-RODS
59.	Asphalt Tack Oil Dipstick	NMD-TOT-DP-STK
60.	Asphalt Tack Oil Temperature Gauge	NMD-ANT-TTD-1510060
61.	Hydraulic Control Panel	NMD-HOF-1033
62.	Hydraulic Doors	MSID-4
63.	Remote Throttle Cable	307141-0-300
64.	Asphalt Tack Oil Spray Wand Deanman Valve	NMD-TOT-WND-VLV
65.	Asphalt Chute Assembly	NMD-ACA
66.	240-Volt 9 K.W. Electric Heater	NMD-CRMLX-9KW
67.	Hydraulic Lift Platform Check Valve	NMD-HYD-LFT-VLV
68.	Hand Propane Torch Manual Shut-Off Valve	WE-V-218
69.	Diesel Fuel Hose Reel	NMD-DFHR-SB3BI-02
70.	Anti-Bridge Bar Section	NMD-ABB-6-51
71.	Hydraulic Tool Hose Reel	NMD-HTHR-SF5E2-07/05
73.	10-Gallon Waste Oil Tank	Built into the right fender
74.	Asphalt Tack Oil Check Valve	NMD-TOT-CHK-VLV
75.	Hydraulic Breaker (72# standard)	BR72125
76.	Hand Propane Torch Shut-Off Solenoid Valve	LPG-7008B
77.	Sanding Chute Assembly	NMD-SNDR-CHUT-ASS
78.	Sanding Chute Motor	Char-Lynn-101-1025
79.	Sanding Chute Hoses	NMD-SNDR-HS
80.	Anti-Bridge Bar Center Support Shaft	NMD-ABB-CNTR-SUP-14
81.	Anti-Bridge Bar Center Support Bearing	CL-25-x-1.5
82.	Asphalt Tack Oil Motor Coupling	NMD-LO-95-C
83.	Diesel Fuel Hand Spray Wand	NMD-DFT-SPR-WND-C
84.	Screw Conveyor Motor Coupling	NMD-SC-DRV-20K
85.	Anti-Bridge Bar Motor Coupling	NMD-ABB-DRV-16K
86.	Anti-Bridge Bar Front Drive Shaft	NMD-ABB-FNT-DRV-10
87.	Waste Oil Tank Fill	Built into the right fender
88.	Waste Oil Tank Drain for Spray Wand	Built into the right fender
89.	Asphalt Tack Oil Spray Wand Nozzle	H3180-5015
90.	Trash (Spoils) Bins	NMD-TRSH-BN
91.	Hydraulic Arrow Board Assembly	NMD-HYD-ARWBRD-ASS
92.	Hydraulic Arrow Board Lens Hood	2001773
93.	Hydraulic Arrow Board Display Section	3002100
94.	Hydraulic Arrow Board Cylinder	PMC-5436
95.	Strobe Light	WHLN-800A

ITEM	DESCRIPTION	PART NUMBER
96.	Propane Tank Remote Gauge	NMD-PRPN-GA
97.	Propane Remote Fill Box Assembly	NMD-PRPN-BX
98.	Propane Tank Fill Adapter	NMD-PRPN-FLA
99.	Diesel Pump	OE-40100
100.	Hydraulic Door Clearance Light	65A-05122
101.	Hydraulic Door Hinge Rubber	NMD-HYD-DR-RBR-KT
102.	Hydraulic Door Seal	NMD-HYD-DR-SEAL-KT
103.	Hydraulic Door Hinge Assembly	NMD-HYD-DR-HNG-ASS
104.	Hydraulic Door Guide Roller Assembly	NMD-HYD-DR-RLR-ASS
105.	Clearance Light	65A-05132 (Amber), 65-05122 (Red)
106.	Screw Conveyor Rear Shaft	NMD-SC-RER-SUP-14.5
107.	Diesel Tank Fill Spout	Included in the diesel tank
108.	Propane Safety Shut Down Light	SQ-D-9001 or 12
109.	Radiant Heat Transfer Oil Fill Vent	NMD-YEL-FL-VNT
110.	Asphalt Tack Oil Fill Vent	NMD-TOT-FLL-BRTHR
112.	Anti-Bridge Bar Rear Shaft	NMDABB-RER-SUP-8

Parts List for Electrical Drawing for UD 425-120

ITEM	DESCRIPTION	SPECIFICATION	PART NUMBER
1.	On-Off-On Switch	10 Amp-DPDT	5592
2.	Thermostat	0-550 degrees Digital	NMD-ANT-TIC-151-R
3.	Solenoid Valve Orifice	12 Volt DC 6 Watt 1/4" (53)	LPG-7008B-D-53
4.	Solenoid Valve	12 Volt DC 6 Watt 1/4"	LPG-7008B-12V
5.	Solenoid Valve	12 Volt DC 6 Watt 1/4"	LPG-7008B-12V
6.	Terminal Block	8 Lug 10 Amp 250 Volt	89-081
7.	10-Second Time Relay	On Delay 12 VDC	NMD-APC-841B
8.	Printed Circuit Board	Spark Emitting Unit	05-306436-753
9.	Safety Shut Down Light	12 Volt Red Lens	9001-OR-12
10.	Ignitor Probe Assembly	High Voltage Spark Sensor	22-100000-540
11.	Elec. Heater Contactor	240 Volt AC-240 AC 50 AMP	8910-LO-2/240
12.	Spark Wire	High Volt-Wire 25KVDC 250 C	05-125948-148
13.	Elec. Heater Power "On"	240 Volt Amber Color	9001-KP-7
14.	Elec. Heater Outlet	240 Volt AC 50 Amp	7968
15.	Diesel Pump	12 Volt DC	OE-40100
16.	Electric Heater	9KW	NMD-CRMLX-9KW
17.	Electric Heater Switch	10 Amp-SPST	5591
18.	Asphalt Pump Safety Relay	12VDC-DPDT	K10PI1DI5
19.	12 Volt DC Battery (Truck Power Supply)	
20.	Propane Fuel Gauge	2" dia. 12 volt DC E-to-F	NMD-LPG-2647
21.	Thermometer	0-550 Degrees Digital	NMD-ANT-TID-1510060
22.	Solenoid Valve Relay	12 Volt DPDT Relay	KI0PI1DI5
23.	2 Amp Rectifier	12 Volt DC Rectifier 2 Amp	D-A-31234
24.	Hand Propane Torch Switch	10 Amp-SPST	5591
25.	Rectifier Supply Relay	12VDC-DPDT	KI0PI1DI5
26.	Electric Heater 12 Volt Relay	12VDC-DPDT	KI0P11D15
27.	Thermocouple	2 Lead 72" long 1/4" dia.	NMD-EM-G706J
28.	Thermocouple	2 Lead 72" long 1/4" dia.	NMD-EM-G706J
29.	Night Temp Timer	Night Temperature Timer	NMD-EC7001
30.	Hand Propane Torch Switch	10 Amp-SPST	ITLI-2
31.	Propane On-Off-On Switch	10 Amp-4PDT	4TL1-I
32.	Hopper Clean Switch	10 Amp - SPST	ITLI-2
33.	Night Temp Timer Relay	12VDC-4PDT	KHAU-17DI1-12
34.	Hopper Cleaning Pump	12VDC-3GPM	NMD-SHRFLW

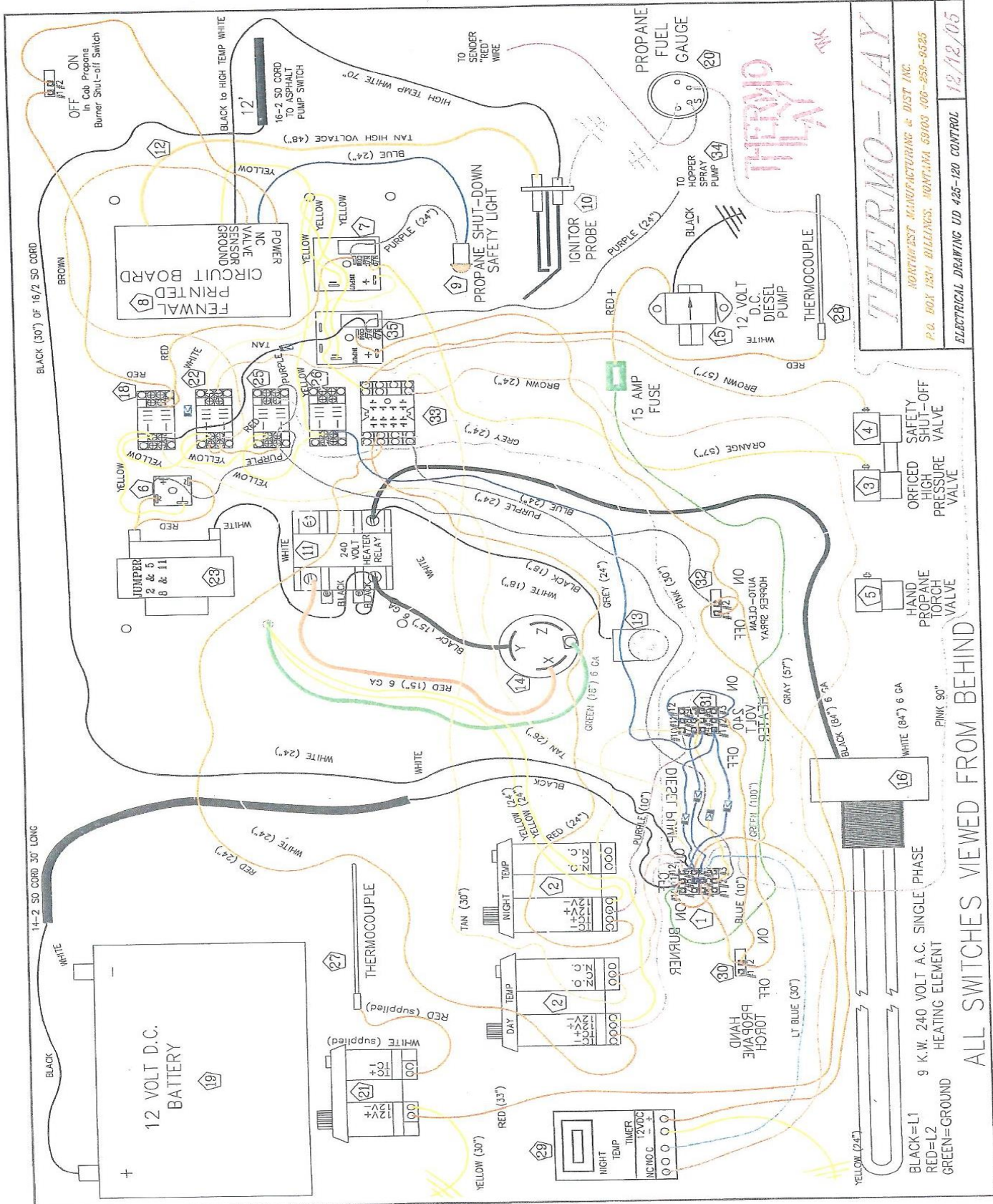

HERMOTHO-LAY

NORTHEAST MANUFACTURING & DIST. INC.
 P.O. BOX 1331 BILLINGS, MONTANA 59103 406-859-6525

ELECTRICAL DRAWING UD 425-120 CONTROL 12/12/05

ALL SWITCHES VIEWED FROM BEHIND

BLACK=L1
 9 K.W. 240 VOLT A.C. SINGLE PHASE
 RED=L2
 HEATING ELEMENT
 GREEN=N=GROUND

REAR CONTROL BOX
VIEWED FROM BACK SIDE

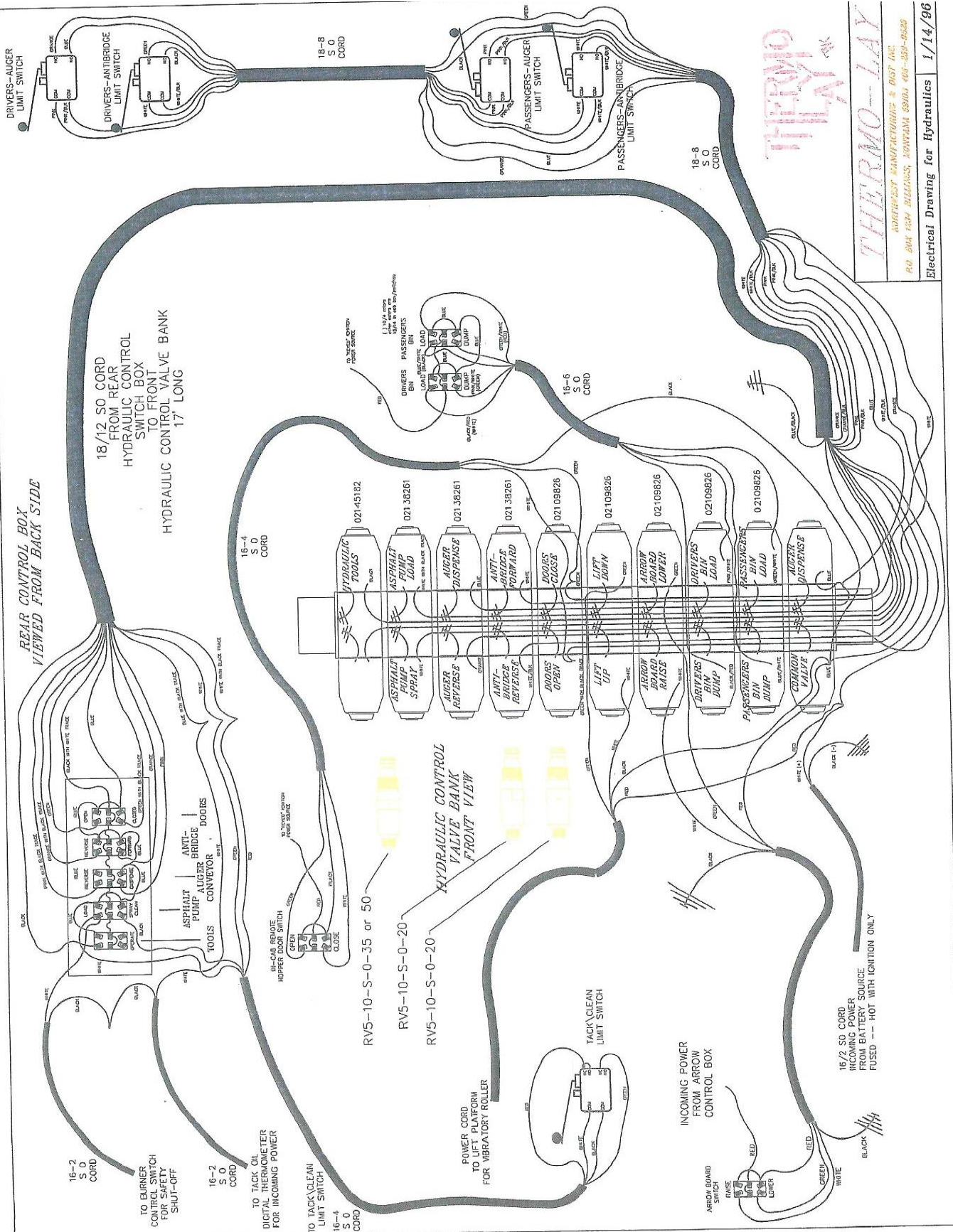

TIPTOP
THERMO-LAY

THE THERMO-LAY
INDUSTRIES MANUFACTURING & DISTRIBUTION
P.O. BOX 1000 BELLINGHAM, WASHINGTON 98220 425-338-9638

Electrical Drawing for Hydraulics 1/14/96

Closed Center 10 bank
 Double auger
 Special Build-up
 6/6/2015

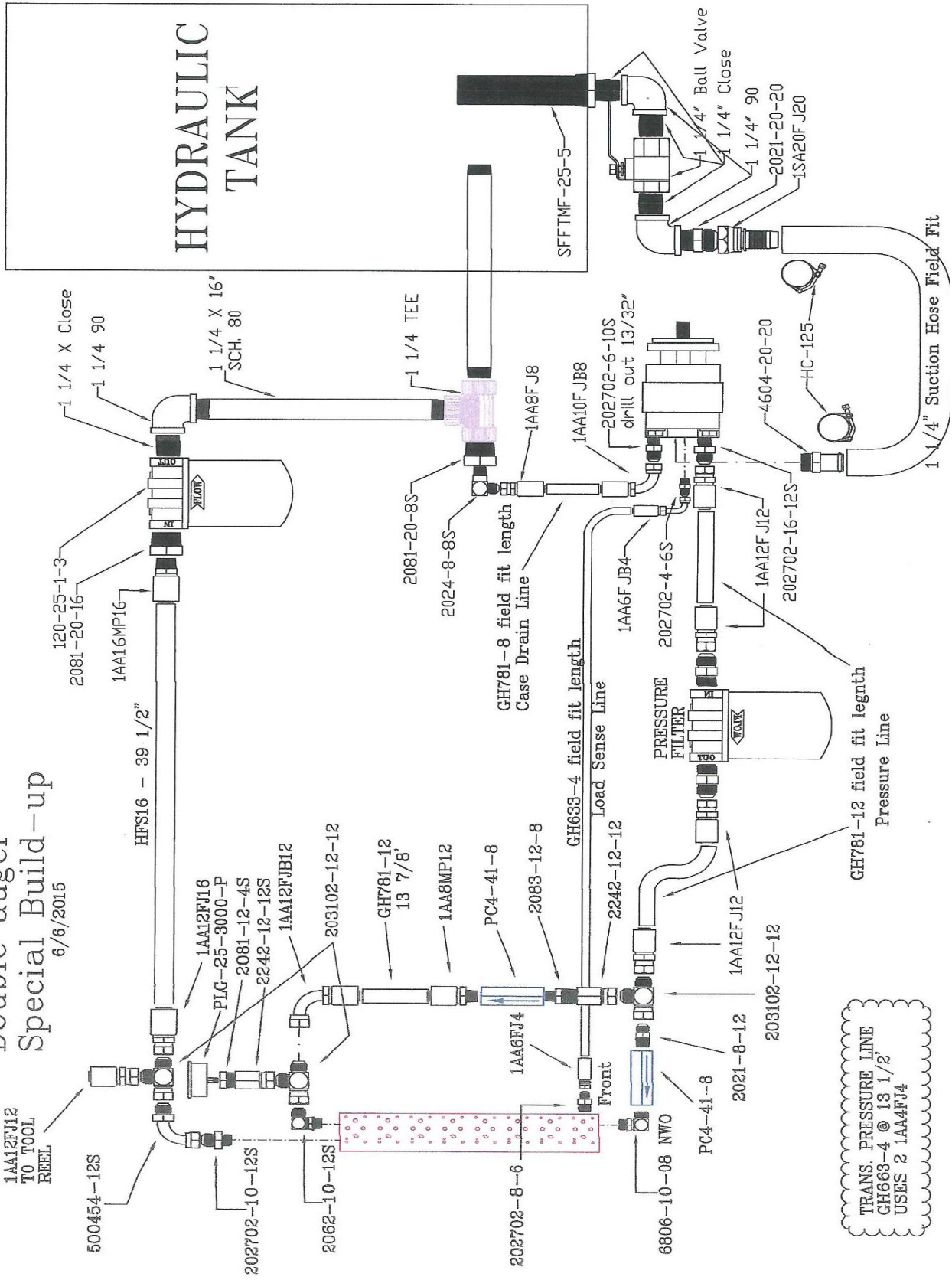

TRANS. PRESSURE LINE
 GH663-4 @ 13 1/2"
 USES 2 1AA4FJ4

Auto-Clean Hopper Cleaning System - Operating Instructions

1. Ensure that the Auto-Clean Hopper Cleaning tank is filled with the desired fluid. The recommended fluid is the Thermo-Lay TS-20 release agent, as it is biodegradable and designed to penetrate asphalt and adhere to steel surfaces without allowing other substances to stick to it. This creates a friction-reducing surface that repels asphalt, making operation easier and reducing wear on the screw conveyor and hopper. However, you can use a substitute fluid such as a citrus-based cleaning fluid if desired. Note that using diesel fuel may appear to clean the components but can actually dilute the asphalt and accelerate the baking process, turning it into carbon or coke. The TS-20 fluid does not affect the asphalt or cause baking.

2. Move the Auto-Hopper Cleaning switch to the "ON" position. The cleaning fluid will spray for 25 seconds automatically. If you require more fluid, you can temporarily move the switch to the "OFF" position for a few seconds and then reset it back to the "ON" position for another 25 seconds of spraying.

NOTE: There is a filter on the discharge side of the pump to prevent small contaminants from clogging the spray bar nozzles. It is recommended to periodically check the spray pattern inside the hopper to ensure that the nozzles are not clogged. If needed, the nozzles can be removed for cleaning.

When the pump is spraying, the propane burner will temporarily stop burning. However, once the pump has finished spraying, the burner will automatically reignite.

These instructions should help you effectively utilize the Auto-Clean Hopper Cleaning System for coating the hopper with the desired fluid and maintaining optimal operation.

Asphalt and Tack Oils

Asphalt is an organic engineering material that has been used since ancient times as an adhesive and waterproofing material. It finds extensive applications in road construction, roofing, repair work, rubber and adhesive compounds, insulation, and more. The terms "bitumen" and "asphalt" are often used interchangeably, but the ASTM (American Society for Testing and Materials) has defined them separately:

- Bitumen: Mixtures of hydrocarbons of natural or pyrogenous origin, or a combination of both, accompanied by their non-metallic derivatives. They can exist as gases, liquids, semi-solids, or solids and are soluble in carbon disulfide.
- Asphalt: A cementitious material that is dark brown to black in color and solid or semi-solid in consistency. The main constituents of asphalt are bitumen, which occurs naturally or is obtained by refining petroleum.

The term "asphalt" also includes the crude mixture of bitumen with impurities like silt, clay, or mineral matter. Natural asphalt refers to asphalt found in its impure forms in nature, such as Cuban, Trinidad, or other deposits. Natural bitumen's, such as wurtzilite, gilsonite, imposnite, elaterite, and grahamite, are also occasionally referred to as natural asphalt.

One of the largest deposits of asphalt is found in the tar sands of Canada, covering an estimated area of 30,000 square miles. Commercially, there are six types of asphalt:

COMMERCIAL ASPHALT

1. Natural bitumen (high purity): Often referred to as "natural bitumen" or gilsonite, these are mined as a solid and primarily used in special lacquers in the insulation field.
2. Natural impure asphalts: Examples include Trinidad and Bermudez Lake asphalts, which contain a significant amount of fine colloidal clay, lava, and other mineral matter.
3. Petroleum or oil asphalts: These are the most widely used types of asphalt today. They are obtained by vacuum and steam distillation of asphaltic base petroleum, resulting in "straight run" or paving asphalt. The process also produces soft or fluid residues known as flux.

4. Roofing or "blown" asphalt: This type is produced by oxidizing a "straight run" petroleum residue or flux using air at elevated temperatures. It yields specialty asphalt used in roofing with rubber or gel-like properties.
5. Cracked asphalt: Cracked asphalt is the by-product of oil-cracking operations. The fluid residuum or cracking coal tar, either used as road oils or steam-reduced to a hard consistency, falls into this category. These materials are highly susceptible to temperature changes.
6. Asphalt emulsions: These emulsions consist of asphaltic bitumen and find wide application in creating water-repellent surfaces. They are used in road construction, roofs, floors, impregnation of paper and fabric, electrical and heat insulation, as binders for insulating materials like cork or asbestos, and even for charcoal briquets and carbon electrodes.

While not all six types are described in detail, this information provides an overview of the various types of asphalt and their industrial applications. The bulletin proceeds to discuss No. 6, "Asphalt Emulsion," as one of the most important types.

ASPHALT EMULSIONS

Asphalt emulsions are mixtures of very small asphalt droplets dispersed in water. The droplets typically have diameters ranging from 1 to 5 microns (1 micron equals 0.001 mm). A satisfactory asphalt emulsion appears smooth and is usually brown in color. They were commercially developed in the early 20th century and are primarily used in road construction and maintenance, soil stabilization, and other applications where cold application of asphalt is desired.

Asphalt emulsions can be made from a wide range of asphalt consistencies, but most commercial road building emulsions are produced using materials with a penetration of 100 to 200 at 77°F (25°C). Harder asphalts may be used for specific industrial or specialized purposes, but achieving a uniform and stable product can be challenging.

There are different types of asphalt emulsions based on the emulsifying agents used:

1. CLAY EMULSIONS: These emulsions contain an aqueous dispersion of a mineral, often bentonite clay. Bentonite clay has exceptional colloidal properties and is commonly used. Other mineral powders or mixtures, such as dry coal, oil shale, Portland cement, metallic oxides, asbestos, and phosphate minerals, have also been patented as suitable emulsifiers for asphalt.

2. ANIONIC EMULSIONS: In anionic emulsions, the surfaces of the asphalt droplets carry negative charges. Soap and surface-active materials are used as emulsifiers in alkaline aqueous dispersions or solutions. Sodium and potassium soaps derived from rosin refining by-products, as well as the soaps of complex high molecular weight organic acids, are extensively used. Colloidal materials like casein and vegetable proteins dispersed in the alkaline phase are also employed to create stable anionic emulsions.

3. CATIONIC EMULSIONS: Cationic emulsions are a newer type of emulsion in the industry. In these emulsions, the surfaces of the asphalt droplets carry a positive charge. The water phase of cationic emulsions is acidic, unlike the alkaline water phase in anionic emulsions. Mixing the two types of emulsions results in the immediate coalescence of the asphalt particles. Cationic emulsions have the ability to adhere well to various types of aggregates and show rapid initial set, minimizing loss due to rainfall. Cationic and anionic emulsions must be handled and stored separately because of their opposing chemical properties.

The stability of an asphalt emulsion depends on various factors, such as water loss, chemical reactions, agitation, heating, freezing, and specific application. Factors affecting stability may differ based on the type of emulsion and the circumstances, whether it's storage, transportation, or application on a solid surface like stone.

Overall, asphalt emulsions offer advantages in cold applications and have specific properties that make them suitable for different purposes in road construction, soil stabilization, and various specialized applications.

The consistency of asphalt emulsions is primarily influenced by three factors:

1. **Asphalt Content:** The amount of asphalt in the emulsion affects its viscosity. Dilution or a decrease in asphalt content leads to a decrease in viscosity, allowing for easier workability. Asphalt emulsions can be easily adjusted to desired consistencies by adding water.
2. **Asphalt Particle Size and Size Distribution:** The size and size distribution of asphalt particles play a role in the flow properties of emulsions. If the particles are round and uniform in size, the maximum volume of asphalt in the system is 74%. A tight arrangement of asphalt spheres with each drop in contact with 12 others is achieved. The size distribution of asphalt drops can impact the viscosity of the emulsion, with a broader distribution associated with lower viscosity. Processing methods can be employed to modify particle size distribution without changing asphalt content, thereby regulating viscosity.
3. **Lyosphere Surrounding the Asphalt Droplet:** The lyosphere refers to the material surrounding the asphalt droplet. The amount of material adsorbed at the asphalt surface and the presence of bound water influence the consistency of the emulsion. Even small amounts of protein stabilizers can lead to significant variations in viscosity. The water present in the emulsion acts as a diluent and carries the emulsifier and stabilizer to the surface of the asphalt particle, affecting emulsion consistency.

The preparation of asphalt emulsions involves several considerations. Commercial manufacturing typically employs continuous operations using rugged equipment such as colloid mills or modified Viking pumps. The horsepower of the mixing unit depends on factors such as gallons per minute, pump RPM, and the viscosity of the asphalt emulsion. Storage facilities are necessary to maintain the emulsion in a fluid state at temperatures around 200 to 250°F (93 to 121°C). Saponifiable materials may be added to the hot asphalt to aid emulsification, while emulsifier solutions are prepared separately. Pumps are used to deliver asphalt and aqueous solutions to the mixer or colloid mill, and preliminary blending can occur through various methods depending on the desired volume and particle size requirements.

There are three general classes of asphalt emulsions commonly used: RS (rapid setting), MS (medium setting), and SS (slow setting) emulsions. Each class has specific viscosity grades, and their uses are as follows:

1. RS-1: Low viscosity for penetration and surface treatment.
2. RS-2: High viscosity for surface treatment.
3. MS-1: Low viscosity for retread mixes with coarse aggregate.
4. MS-2: Medium viscosity for plant mixers with coarse aggregates.
5. SS-1: For fine aggregate mixes.

Asphalt emulsions find applications in various fields, including road building and maintenance. Different grades of emulsion are used for different types of road construction, ranging from plant mixes to penetration work and surface treatment. Emulsified asphalt has also been used to stabilize the base under concrete roads.

Additionally, asphalt emulsions have special uses such as waterproofing masonry and concrete foundations, as well as waterproofing and insulating roofs. They can also provide protection to wood and metal surfaces, preventing atmospheric deterioration and corrosion.

In certain cases, emulsified asphalt-earth mixtures have been used in construction projects, such as dwellings and other buildings. Stabilized blocks made of emulsified asphalt and earth are laid together to form thick walls. During wartime, protective walls were constructed using emulsified asphalt, offering resistance to artillery and machine gun fire. Emulsions have also been employed to stabilize the sand and loosely packed soil under structures and railroad tracks, creating a flexible mat resistant to movement caused by underground water.

Research in the field of asphalt emulsions has made significant progress, particularly in the application of physical and colloidal chemistry. The study of the complex arrangement of emulsifier, stabilizer, and bound water surrounding the asphalt droplets is ongoing. Supersonic vibrations are being explored as a means of emulsifying asphalt. Improvements in commercial manufacturing and the evaluation of emulsions for specific purposes present immediate and practical challenges.

The viscosity of asphalt emulsions can be found in charts provided by the ASTM, particularly on pages 47 and 48 of the referenced document.

FILLED ASPHALTS

Apart from asphalt emulsions, there are also mixtures of bitumen and pulverized material known as filled asphalts. The properties of pulverized minerals (fillers) and their impact on the rheological properties of filled asphalt are discussed. Particle size, size distribution, particle shape, surface configuration, surface area, packing of particles, void content, and average void size in the compacted powder are among the primary and secondary properties of the minerals that influence the consistency and flow characteristics of filled asphalts.

PARTICLE SHAPE: Evaluating particle shape in absolute terms is challenging, as it may vary for different-sized particles within a particular powder. Microscopic examination can provide insights into particle shape, and determining the thickness of particles can be done using a microscope equipped with a micrometer adjustment on the eyepiece. Particle shapes can range from smooth to irregular granules, plates, and fibers, all of which affect the properties of asphaltic mixtures.

Cutback asphalts and road oils are used in road construction and maintenance. The basic theory behind their use is straightforward: cutback asphalt is a solution of asphalt in a volatile solvent. When this solution is applied to surfaces like stone, wood, metal, or others, the solvent evaporates, leaving behind a film of asphalt that acts as a binder or coating.

To reduce the viscosity of asphalt for application, two methods are commonly used: heating and dissolving the asphalt in a suitable solvent. Various organic liquids can serve as solvents for asphalt, but they need to be relatively innocuous and possess a flash point above 80°F (27°C) to ensure safety. The solvent should also have a surface tension high enough to facilitate solubilizing action on the asphalt.

Different formulations of cutback asphalts have been developed over the past 50 years for road construction and highway maintenance. They are classified into three general types: rapid curing (RC), medium curing (MC), and slow curing (SC). The specific type of cutback asphalt is determined by the desired application and the properties required.

The viscosity of each cutback asphalt depends on the type and amount of solvent used. The characteristics of the asphalt itself also play a significant role in the properties of the resulting solution. The viscosity of the cutback asphalt determines the temperatures at which it can be sprayed or mixed.

Rheological properties, particularly the flow behavior, of asphalt, are influenced by the volume percent of mineral powder present in the mixture. The addition of mineral fillers to asphalt can increase its brittle strength. Different mineral powders with varying particle shapes and textures can be blended with asphalt to create filled asphalt with superior properties. Blending powders with approximately the same three dimensions, such as micaceous minerals or fibrous minerals like asbestos, is a common practice.

MIXED FILLERS in asphalt have been primarily used in asphalt plastics and mastics, but recent developments have expanded their use in roofing materials to improve flow and other desirable properties. Employing mixed fillers can result in a superior binder for the coarse aggregate in the pavement, allowing for the advantageous use of 2-3% more asphalt without undesirable flow properties. Rheological studies of asphalt offer promising avenues for further investigation and understanding.

In summary, cutback asphalts and road oils are used in road construction and maintenance. They involve the application of a solvent-based solution that evaporates, leaving behind a binder of asphalt. The viscosity and properties of the cutback asphalt depend on the type and amount of solvent used, while the addition of mineral fillers can enhance the performance of asphalt by increasing its brittle strength and providing other desirable characteristics.

TO REDUCE THE VISCOSITY OF ASPHALT PRIOR TO APPLICATION, THERE ARE TWO METHODS:

1. Heating: Asphalt can be heated to reduce its viscosity. Heating makes the asphalt more fluid and easier to handle. The specific temperature required for heating depends on the type and grade of asphalt being used and the desired application.

2. Dissolving in a suitable solvent: Another method is to dissolve the asphalt in a suitable solvent. This process involves mixing the asphalt with a volatile organic liquid that acts as a solvent, reducing the viscosity of the asphalt. The solvent must possess certain properties such as being relatively innocuous, having a flash point above 80°F (27°C), and having a surface tension high enough to facilitate solubilizing action on the asphalt.

There are numerous organic liquids that can serve as solvents for asphalt, but the choice of solvent depends on factors such as cost, availability, and safety. Carbon disulfide and benzene are effective solvents for asphalt, but they are expensive, flammable, and toxic, making them unsuitable for commercial use. Some sulfur, chlorine, and nitrogen compounds are also good solvents for asphalt but are not commercially viable due to various reasons.

The solvent used for dissolving asphalt must possess the required boiling range, flash point, and chemical characteristics. Petroleum oil or naphtha is commonly used for this purpose in the United States, and it should contain certain aromatic compounds to meet the chemical requirements.

Different formulations of cutback asphalts have been developed over the past 50 years for road building and highway maintenance. These formulations are classified into three general types based on their curing rates: rapid curing (RC), medium curing (MC), and slow curing (SC). The specific type of cutback asphalt used depends on the desired application and the properties required. Charts are available that show the viscosities of various grades of asphalt at different temperatures, providing guidance on the heating requirements for spraying or mixing.

Rapid curing (RC) cut-back asphalts are designed to have the solvent disappear quickly, leaving a film of asphalt on the solid surface. They are often made from 85 to 120 penetration asphalts for road building purposes. The choice of the appropriate cutback asphalt depends on the specific project requirements and the desired performance characteristics.

The Medium Curing (MC) cut-back asphalts are prepared from slightly softer asphalts with penetration grades ranging from 120 to 300. These materials use a less volatile solvent compared to Rapid Curing (RC) cut-backs.

On the other hand, Slow Curing (SC) cut-back are considered less important in terms of volume. If a suitable stock charge is available, the slow curing materials can be drawn directly from the still. Otherwise, an asphalt is mixed with a high flash oil of low volatility to create the slow curing cut-backs.

The viscosity of each cut-back asphalt depends on the type and amount of solvent used. The characteristics of the asphalt itself also play a significant role in the properties of the solution or dispersion. The following are the general uses of cut-back asphalts based on their types:

RAPID CURING (RC):

1. RC-0 through RC-5: Used as a binder in surface treatment.
2. RC-1 through RC-3: Used as a binder in road mix construction with open graded aggregates.
3. RC-2: Used as a binder in cold patch mixtures.
4. RC-1 through RC-5: Used as a binder in cold-laid plant mix materials.
5. RC-5: Used as a binder in penetration of macadam construction under cold weather conditions.

MEDIUM CURING (MC):

1. MC-0 through MC-2: Used as a priming material.
2. MC-2 through MC-5: Used as a binder in surface treatments.
3. MC-3 and MC-4: Used as a binder in road mix construction with open graded aggregates.
4. MC-2 and MC-3: Used as a binder in road mix construction with dense-graded aggregates.
5. MC-3 and MC-4: Used as a binder in cold patch mixtures with open graded aggregates.

6. MC-2: Usually used as a binder in cold patch mixtures with dense-graded aggregates.
7. MC-3, MC-4, and MC-5: Used as a binder in cold-laid plant mix construction with dense-graded aggregates.

SLOW CURING (SC) products, often called "road oils," are typically residual materials produced from the fractional distillation of certain crude petroleum. They contain a mixture of asphalt and oil, and the consistency depends on the amount and character of the oil. Slow-curing asphalt materials can be prepared by blending asphalt cement with an oily petroleum fraction.

Most asphalt cut-backs are manufactured using the batch process. A suitable solvent is pumped into a vessel, followed by the addition of hot "fluid asphalt." The components are mixed using mechanical agitation, and adhesives or additives may be blended into the cut-back once the approximate formulation is reached. Continuous blending procedures can be employed for large volumes to avoid the need for extensive tankage investment.

Important decisions need to be made before manufacturing asphalt cut-backs, such as selecting a suitable asphalt and solvent. The desired properties and drying rate of the cut-back are influenced by the volatility of the solvent. Solvents with aromatic naphthenic compounds promote faster drying and better dispersion of the harder asphalt components, allowing the cut-back to return to its original viscosity over time. It is not advisable to use high non-Newtonian asphalt for cut-back manufacturing, as it may lead to gelation during storage or shipment. Similarly, asphalts derived from highly cracked materials are not suitable for cut-back manufacturing.

CUT-BACK ASPHALTS

In road construction, both cold plant mixtures and hot mixed/hot-laid mixtures utilize cut-back asphalts and road oils. The use of Viking pumps is necessary to move the asphalt in both methods.

The evaluation of bituminous mixtures in road construction involves various methods, including:

1. Unit weight vs. asphalt content: This method examines the relationship between the weight of the mixture and the amount of asphalt used.
2. Stability vs. asphalt content: It assesses the stability of the mixture by varying the asphalt content.
3. Percent of voids: This method measures the percentage of void spaces in the mixture, which affects its durability and performance.
4. Total mix vs. asphalt content: It analyzes the overall composition of the mixture concerning the asphalt content.
5. Percent of voids aggregate vs. asphalt content: This method focuses on the void spaces within the aggregate portion of the mixture in relation to the asphalt content.
6. Flow value vs. asphalt content: It measures the flow characteristics of the mixture based on different asphalt content levels.

In both hot and cold mix road construction, factors such as aggregate properties, drainage facilities, sub-soils, and sub-grades significantly influence the final outcome of the road. However, as this discussion primarily concerns asphalt usage, these factors are not discussed in detail. The main focus is on the composition and properties of asphalt, as well as the pumps required for asphalt and road oils in road building.

The amount of asphalt used in road construction should be sufficient to bind the aggregate effectively and provide satisfactory stability. It is important to seal the pavement against the detrimental effects of air and water. Sometimes, road builders may use too little asphalt due to concerns about overloading the pavement with bitumen, leading to low stability and a slippery surface. However, this approach is undesirable.

In an attempt to avoid such issues, inadequate amounts of binder are sometimes used, especially in the surface course. When the surface course is porous, air can penetrate the structure and oxidize the binder. Oxidation causes the asphalt to harden, and when its viscosity exceeds 10 Poises at 77°F, the asphalt will no longer serve as a suitable binder at low temperatures. As the binder becomes too hard, the pavement surface erodes under the impact of traffic. Even a 0.5% asphalt deficiency in a mixture can result in a road that requires excessive maintenance and materials.

The following descriptions provide an overview of the terms commonly used in asphalt road construction.

SURFACE TREATMENT is a road construction method that involves applying a layer of asphalt onto a stabilized roadway, followed by the application of a properly graded aggregate. The choice of asphalt type for surface treatment ranges from RC-0 to RC-5 and MC-2 to MC-5. In some cases, asphalt cement with a penetration grade of 150 to 300 may be used. The selection of the asphalt type depends on the anticipated traffic conditions.

The thickness of the surface treatment can reach up to 2.5 inches. If multiple courses are applied, larger-size aggregates are used for the first layer, while subsequent layers use aggregates of reduced sizes. During the summer, RC-5 and MC-5 asphalts are commonly used. However, when surface treatment needs to be performed in cool weather, less viscous cut-back asphalts are preferred.

During the application of the surface binder, care must be taken to avoid overlaps, as this can result in uneven road surfaces. To prevent overlaps, the distributor is stopped at a specific point, and the paper beneath it, along with its asphalt coating, is removed before the next distributor arrives. A fresh sheet of paper is then placed on the newly surfaced road, with the edge aligned with the previous stoppage point. The new distributor starts on this paper, ensuring that the two applications join each other on the road without overlapping.

PRIMING is an important step in road construction, where a prime coat is applied to a prepared base. The purpose of the prime coat is to prevent the entry of water and ensure a strong bond between the base and the asphalt surface material. For priming, MC-0, MC-1, and MC-2 asphalts are commonly used. Pressure distributors are typically employed to apply the prime coat. The quantity of prime coat required varies from 0.25 to 0.50 gallons per square yard, depending on the condition of the surface being primed.

SEALCOATING is another road surface treatment used to improve the condition of worn or cracked road surfaces and prevent water penetration into the subgrade. The choice of asphalt type for seal coating depends on the season and the purpose of the application. Hot asphalt cement is suitable for summer applications, while asphalt cutbacks are used when sealing road surfaces during cold weather. The use of asphalt cutbacks allows for easier application and better performance in lower temperatures.

SLURRY SEAL is a type of sealing material that has gained popularity in recent years. It is composed of a mixture of fine aggregates, such as limestone rock dust, combined with diluted and slow-setting asphalt. In many cases, an asphalt emulsion is used for this purpose. A properly formulated slurry seal can be applied in a thin layer, typically ranging from 1/16" to 1/8" thick, to waterproof the surface, seal cracks, and raveled spots, and level small uneven areas on the base surface. It is important to note that a slurry seal should not be applied on a defective base.

PREFABRICATED BITUMINOUS SURFACING (PBS) was developed during wartime as a quick method for surfacing roads and airstrips in areas where conventional construction materials were not readily available. It involves the use of a tough and waterproof membrane that can be rapidly applied. Recent advancements in blending epoxy resin with asphalt have shown promise in addressing challenges posed by heavy loads and fuel spillage. The resulting binder is a black viscous liquid that closely resembles asphalt.

COLD PLANT MIXTURES are prepared in mixing plants using low to medium-viscosity cutbacks or emulsions. The aggregate used is like that used in hot mixtures. RC-1 to RC-5 cutbacks are typically used in conjunction with open-graded aggregates. Cold plant mixtures can be stockpiled for later use or used immediately. When materials made with low-viscosity cutbacks are placed on roads, the mixture must be turned by blading to allow for solvent evaporation. Once the mixture has become stiff, it can be spread on the roadway and compacted to create a durable surface.

HOT-MIXED HOT-LAID MIXTURES are commonly used in road construction and involve a wide range of asphalt materials. Asphalt cement with varying penetration grades, typically ranging from 40 to 300, as well as high viscosity cut-backs like RC-4, MC-4, and SC-4 and 5, are utilized in these mixtures.

Pumps play a crucial role in various stages of asphalt usage. The Viking Pump is recognized as one of the best rotary pumps for this application. Its superiority stems from the mixing or blending action that occurs as the liquids pass through the pump, resulting in a more homogeneous asphalt mixture. The effective blending of the asphalt with the solvent leads to improved outcomes.

One important application of a Viking Pump in asphalt road construction is on the asphalt distributor itself. In this setup, the hot asphalt is pumped by the Viking Pump at a predetermined speed, allowing the pump to meter the required amount of asphalt through a spray bar onto the road surface. The pressure generated by the pump propels the liquid through the nozzles on the spray bar, ensuring even and adequate distribution of the hot asphalt over the road.

Pumps for distributors are typically driven by a separate engine. The speed of the power engine is precisely controlled and coordinated with the corresponding road speed of the distributor to achieve accurate and consistent application of the asphalt.

The manufacturers of various distributors provide charts that show the capacity of the Viking pump operating at a specific speed of the pump engine, correlated to the ground speed of the truck. This ensures the application of a specified amount of asphalt on the road surface.

On a distributor, there is usually a small oil pump that serves a dual purpose. First, it feeds fuel oil into the oil burner, which provides heat to the asphalt. Second, it pumps fuel oil to flush out the distributor pump and spray bar at the end of the day's run.

Viking pumps are used to transfer asphalt from storage to the distributor. They can be mounted on a truck tank or installed at the storage tank. Many distributors have a piping arrangement that allows the distributor pump to transfer asphalt from the transfer truck into the distributor. Pumps are also required to transfer fuel oil to and from the storage vessel.

Viking pumps used in distributor applications vary in size, typically ranging from 200 gallons per minute (GP.M.) to 350 and 375 GP.M. It is common practice to operate Viking pumps on distributors at a speed higher than the rated catalog speed. This is because the asphalt specification often requires spraying at a high temperature to ensure a low-viscosity liquid, the actual operating hours per year are low, and the ratio of the pump weight on the distributor to the payload is favorable.

Asphalt plants that prepare aggregate and asphalt mixtures also rely on Viking pumps to transfer asphalts, solvents, and fuel oil from storage tanks to the plants. The mixed material is usually transported to the construction site in dump trucks. Mobile units that prepare and spread the mixture while moving along the highway also require pumps for asphalt, fuel oil, and solvents. Storage facilities, whether permanent or temporary, for a specific construction site, all require Viking Pumps. Pumps used for storage are typically operated at a slower speed than indicated in the catalog because temperature control is usually not precise.

Viking Pumps are generally trouble-free when pumping asphalt. However, two common problems exist that are beyond the control of the pump manufacturer. First, if the pump is not completely flushed with flushing oil after each use and the asphalt is allowed to harden, the pump must be adequately heated to thaw out the hardened asphalt before starting. Careful supervision of this operation can eliminate the difficulty. Second, packing an asphalt pump presents a considerable challenge. Some types of asphalt with high caustic content can cause difficulties with the packing used. The packing must be resistant to caustic substances in such cases.

Asphalt service is demanding on packing because the hot asphalt liquid progressively penetrates through the voids of the packing during operation. When the operation stops, the asphalt hardens, and upon resuming, it tears the packing and creates larger openings, making it difficult to prevent leakage. Paying careful attention to heating the packing area before restarting operations can help prevent this problem. Mechanical seals for asphalt applications have not been widely accepted.

BASED ON THE PROVIDED INFORMATION, HERE ARE SOME RECOMMENDATIONS FOR ASPHALT EMULSION PUMPS:

NOTE 1:

1. The pump speed and clearance for asphalt emulsion pumps cannot be determined in the same way as for asphalt or asphalt cement. The squeezing action of the pump tends to separate the asphalt from the water, causing the asphalt to adhere to the inside of the pump, including the moving parts. This reduces the running clearances.
2. It appears that there is an equilibrium point in this action where no further buildup occurs.
3. It is suggested that the pump speed should be approximately one-half of the speed determined by the viscosity at the pumping temperature, and the running clearances should be about twice as much as indicated by the viscosity.

NOTE 2:

1. Pumps handling filled asphalts, which are highly abrasive in nature, can present problems. It is recommended to operate these pumps at 1/2 to 1/3 of their rated speed.
2. The use of Tungsten Carbide pins and Ceramic idler bushings has been proven to be highly successful in handling abrasive-filled asphalts.

Please note that these recommendations are based on the provided information and may not cover all specific circumstances. It is always recommended to consult the pump manufacturer or a qualified expert for precise recommendations based on your specific application and equipment.

The writer expresses gratitude and acknowledges that the information contained in this manual on asphalt was gathered from personal notes and various catalogs.

— VISCOSITY SAYBOLT UNIVERSAL SECONDS —

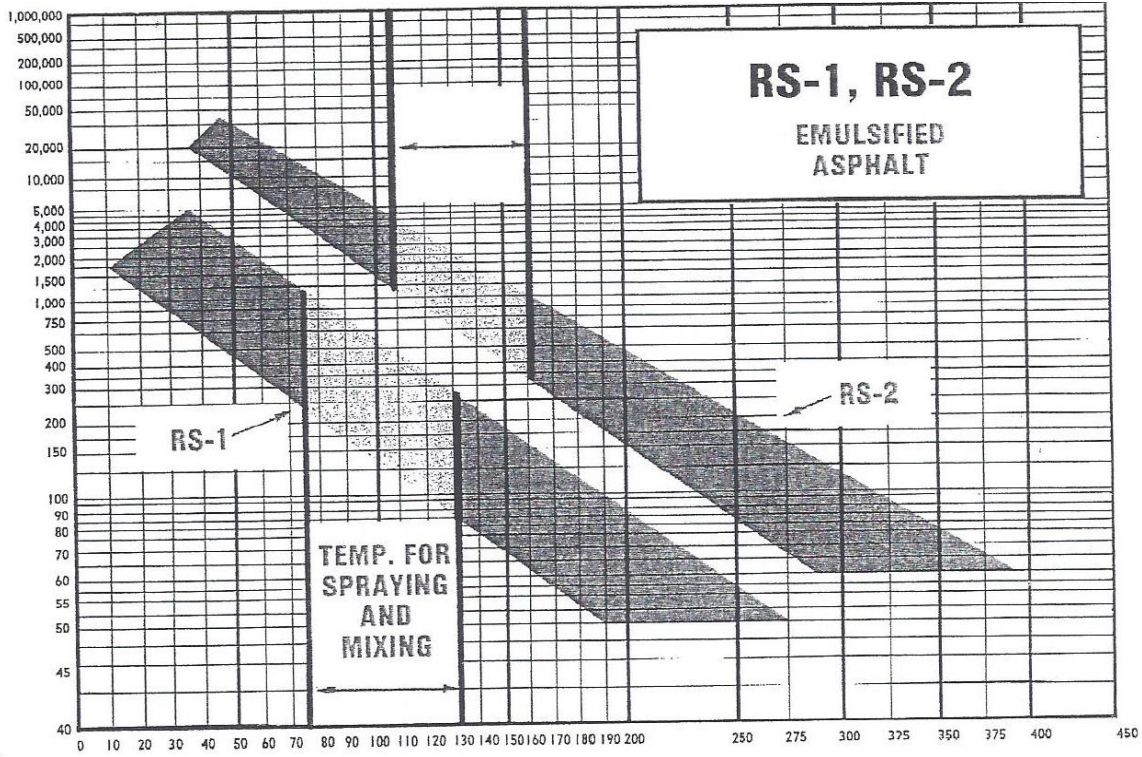

— TEMPERATURE DEGREE FAHRENHEIT —

— VISCOSITY SAYBOLT UNIVERSAL SECONDS —

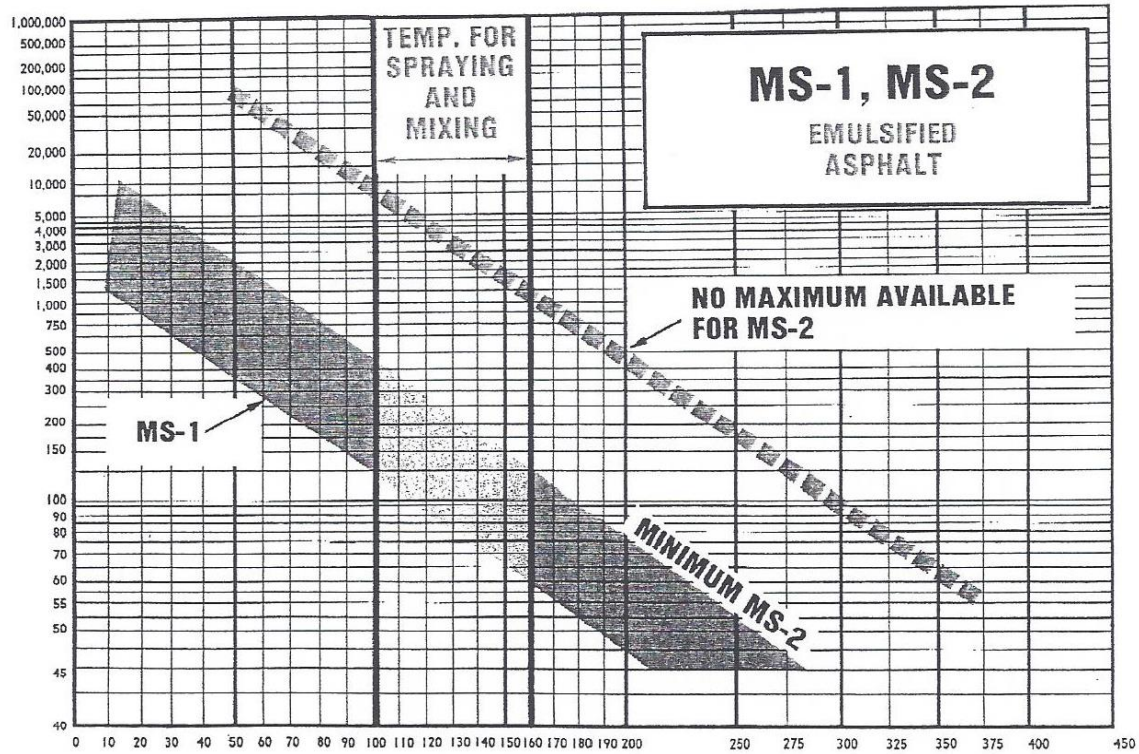

— TEMPERATURE DEGREE FAHRENHEIT —

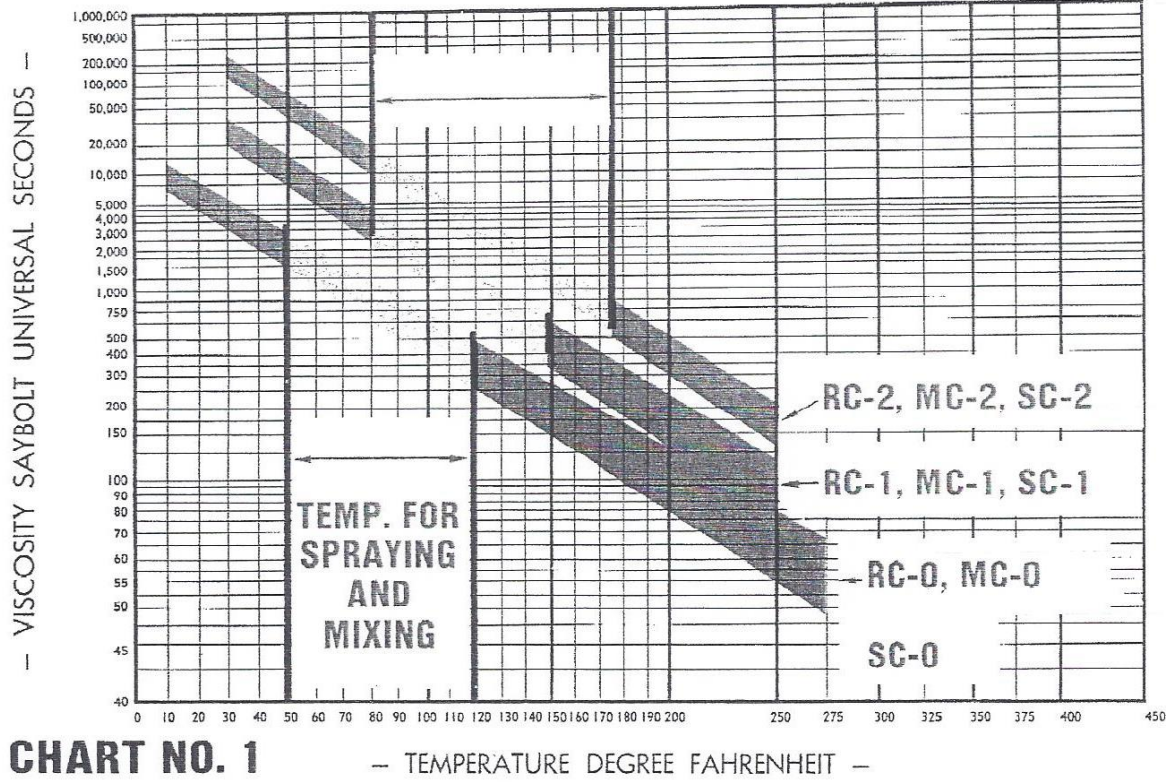
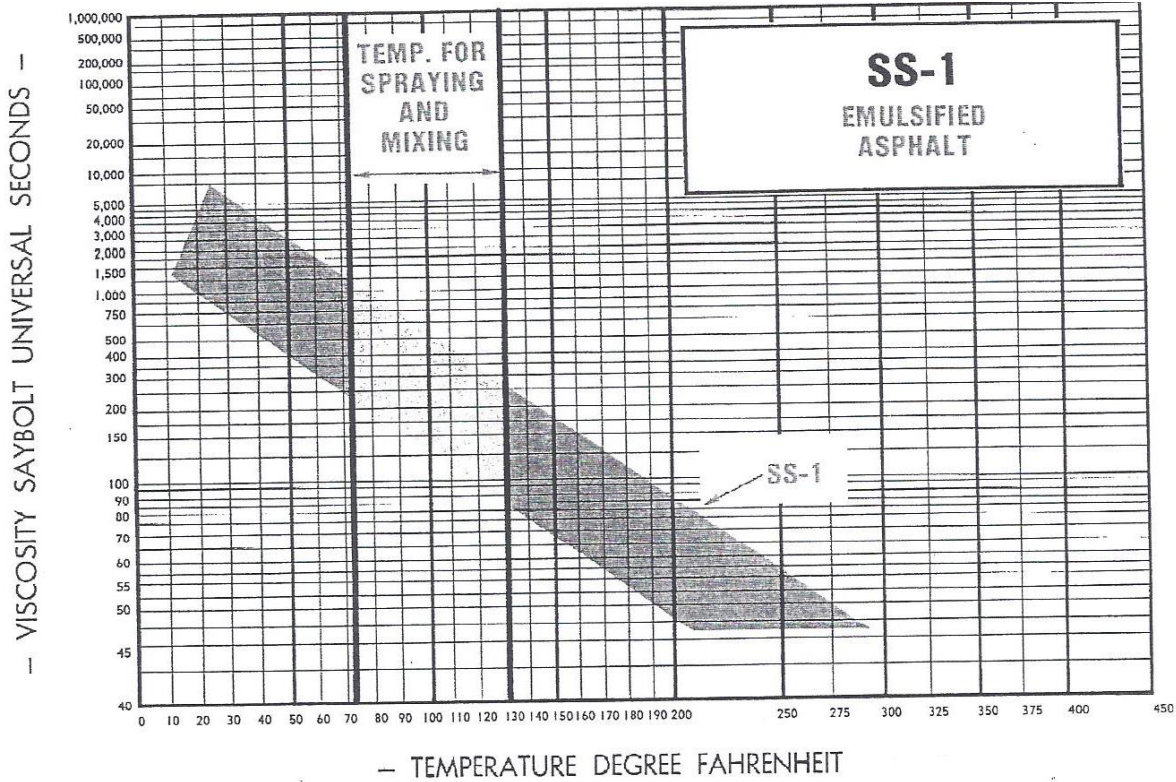

CHART NO. 1

— VISCOSITY SAYBOLT UNIVERSAL SECONDS —

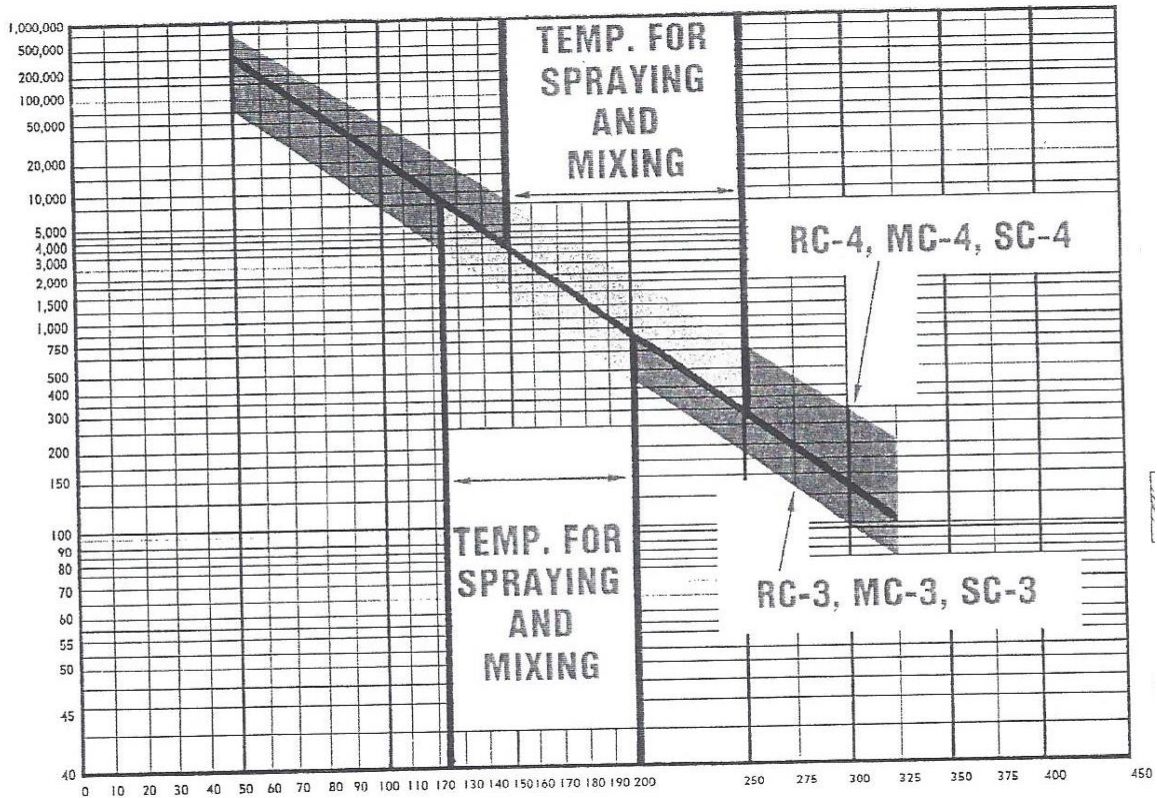

CHART NO. 2

— TEMPERATURE DEGREE FAHRENHEIT —

— VISCOSITY SAYBOLT UNIVERSAL SECONDS —

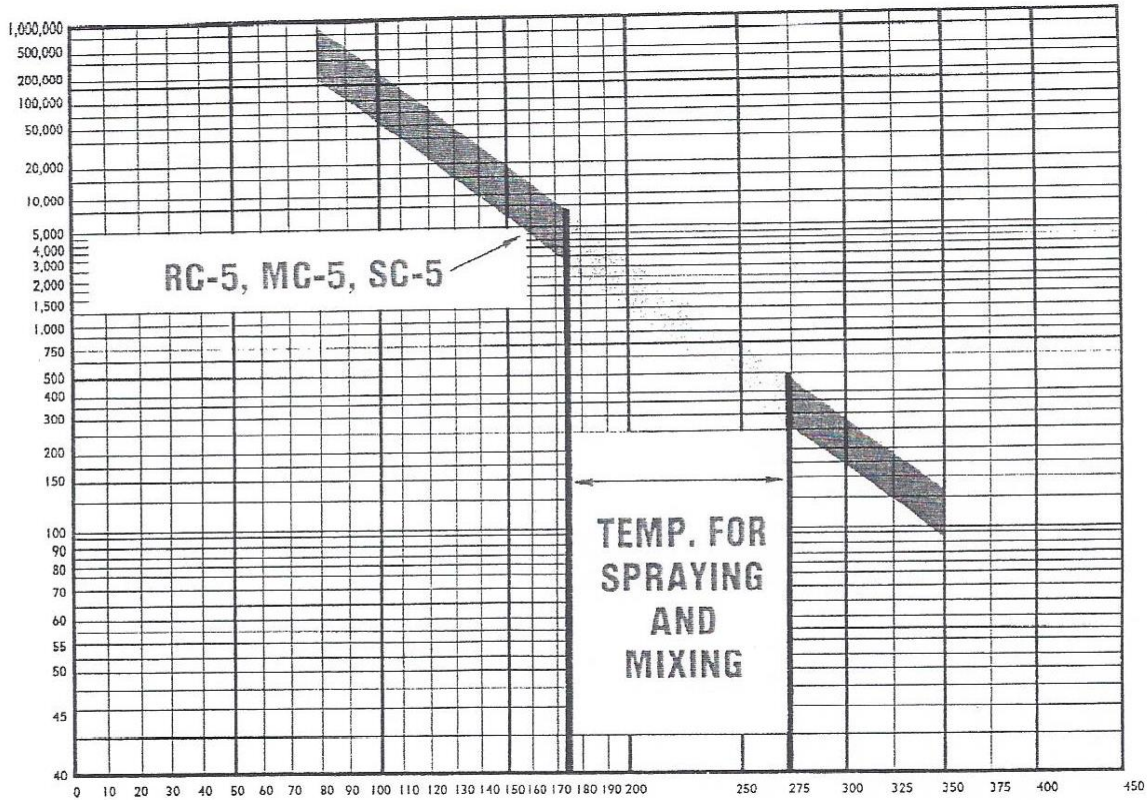

CHART NO. 3

— TEMPERATURE DEGREE FAHRENHEIT —

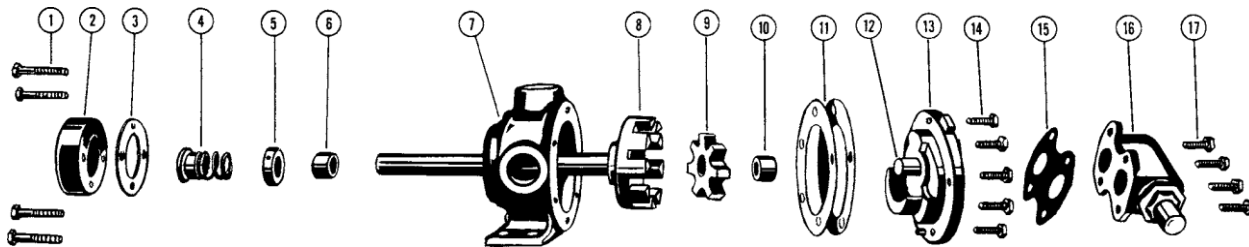

FIGURE 8 - EXPLODED VIEW MODEL H432 AND HL432 PUMP

ITEM	NAME OF PART	ITEM	NAME OF PART	ITEM	NAME OF PART
1	Capscrews for End Cap	7	Casing and Bushing Assembly	13	Head and Idler Pin Assembly
2	End Cap	8	Rotor and Shaft Assembly	14	Capscrews for Head
3	Gasket for End Cap	9	Idler and Bushing Assembly	15	Relief Valve Gasket
4	Mechanical Seal	10	Idler Bushing	16	Relief Valve
5	Set Collar with Setscrew	11	Head Gasket Set	17	Capscrews for Valve
6	Casing Bushing	12	Idler Pin		

DISASSEMBLY

DANGER!

Before opening any Viking pump liquid chamber (pumping chamber, reservoir, relief valve adjusting cap fitting, etc.) Be sure:

1. That any pressure in the chamber has been completely vented through the suction or discharge lines or other appropriate openings or connections.
2. That the driving means (motor, turbine, engine, etc.) has been "locked out" or made non-operational so that it cannot be started while work is being done on pump.
3. That you know what liquid the pump has been handling and the precautions necessary to safely handle the liquid. Obtain a material safety data sheet (MSDS) for the liquid to be sure these precautions are understood.

Failure to follow above listed precautionary measures may result in serious injury or death.

1. Refer to figures 5 through 12 for the name of the parts.

TO DISASSEMBLE THE PUMP AND REMOVE THE HEAD, IDLER, PACKING GLAND, AND MECHANICAL SEAL, FOLLOW THESE STEPS:

1. Mark head and casing: Before disassembly, mark the head and casing to ensure proper reassembly. This marking will help align the components correctly during reassembly. Additionally, note that the idler pin, which

is offset in the pump head, must be positioned toward and at an equal distance between the port connections to ensure proper flow of liquid through the pump.

2. Remove the head capscrews: Begin by removing the head capscrews. Note that if you have a G model, you should first remove the four-valve capscrews, valve, and gasket before proceeding with the removal of the six head capscrews.

3. Take caution with the idler: When removing the head, be careful not to let the idler fall from the idler pin. Tilt the top of the head back while removing it to prevent the idler from detaching. Remove the head from the pump, ensuring that you avoid damaging the head gasket set, as all gaskets are necessary to maintain proper end clearance.

4. Remove the idler and bushing assembly: Next, remove the idler and bushing assembly from the pump. If the idler bushing needs replacement, refer to the instructions for the installation of carbon graphite bushings.

5. Remove the packing gland, packing, and packing retainer washer: Proceed to remove the packing gland, packing, and packing retainer washer from the pump assembly.

6. Remove the mechanical seal (if applicable): If your pump is equipped with a mechanical seal, remove the end cap to expose the mechanical seal.

7. Slide off the mechanical seal: Remove the mechanical seal by sliding it off the end of the shaft. Before doing so, loosen the setscrew in the set collar and remove the set collar.

By following these steps, you will be able to disassemble the pump and remove the head, idler, packing gland, and mechanical seal as needed.

IF YOU NEED TO REPLACE THE CASING, ROTOR BEARING SLEEVE, IDLER BUSHING, OR REPACK THE PUMP, FOLLOW THESE STEPS:

1. Remove the snap ring (if present): Older pumps may have a snap ring on the shaft. Before removing the rotor and shaft, carefully remove the snap ring to ensure smooth disassembly.

2. Remove the rotor and shaft: Take great care when removing the rotor and shaft from the pump to prevent any damage to the casing or rotor-bearing sleeve bushing. Handle these components delicately to avoid any mishaps.

3. Remove old packing, lantern ring, and packing retainer washer: If you are replacing the casing, rotor bearing sleeve, or performing repacking, remove the old packing, lantern ring (if applicable), and packing retainer washer. Note that not all pumps have a lantern ring.

4. Thoroughly clean and inspect the parts: Clean all the disassembled parts thoroughly to remove any debris, dirt, or residue. Once cleaned, carefully examine each part for signs of wear, damage, nicks, burrs, or excessive wear. Pay special attention to the bushings, idler pin, and all other components. If any parts show significant wear or damage, they should be replaced.

By following these steps, you can remove the old packing, inspect the components, and prepare for the replacement of the casing, rotor bearing sleeve, or idler bushing if necessary. Remember to handle all parts with care to avoid causing any additional damage during the disassembly process.

ASSEMBLY

To install the bushing, thrust washers, rotor assembly, and head gaskets, and assemble the head onto the pump, follow these steps:

1. Install the bushing: If you are installing a bushing into the casing or rotor bearing sleeve, ensure it is inserted correctly. If the bushing has a lubrication groove, position it at the 12 o'clock position in the bracket. If you are using a carbon graphite bushing, refer to the specific instructions for its installation.

2. Lubricate the rotor shaft assembly: Apply a coating of non-detergent SAE 30-weight oil to the shaft of the rotor shaft assembly.

3. Start assembling the rotor assembly: Begin by starting the end of the shaft into the bracket bushing. Turn the rotor from right to left while slowly pushing it into the casing. Take care to ensure a smooth and proper fit.
4. Place head gaskets on the head: Put the head gaskets on the head, ensuring you use the correct number of gaskets to provide the necessary end clearance within the pump. Refer to the Gasket Table (Figure 13) to determine the appropriate number of gaskets for your specific pump.
5. Install the idler and bushing: Apply a coating of non-detergent SAE 30 weight oil to the idler pin and place the idler and bushing onto the idler pin in the head. If you are replacing a carbon graphite bushing, follow the specific instructions for its installation.
6. Assemble the head onto the pump: Tilt the top of the head slightly away from the pump until the crescent enters the inside diameter of the rotor. Rotate the idler until its teeth mesh with the rotor teeth. Be careful not to damage the head gaskets during this process. Tighten the head capscrews or nuts and then check the end clearance. If the pump shaft cannot be rotated, add more gaskets. If there is noticeable end play, remove enough gaskets to eliminate the play while still ensuring the pump turns freely.

By following these steps, you can properly install the bushing, thrust washers, rotor assembly, head gaskets, and assemble the head onto the pump. Ensure that you apply lubrication as necessary and check the end clearance to ensure proper functioning of the pump.

PUMP MODEL	NORMAL AMOUNT USED	ONE SET OF GASKETS CONSISTS OF THE FOLLOWING	STANDARD END CLEARANCE
G32 G432	.010" - .015"	2 - .006" 1 - .005" 2 - .002"	.003"
H, HL32 H, HL432	.010" - .015"	2 - .006" 2 - .002"	.003"
J, K, KK32	.015" - .020"	1 - .015" 1 - .010" 1 - .006"	.005"
L, LQ, LL32	.025" - .030"	1 - .015" 1 - .010" 1 - .006"	.005"
LQ32E	.025" - .030"	1 - .015" 1 - .010" 1 - .006"	.010"
Q32	.012" - .030"	2 - .015" 1 - .006"	.010"
Q32E	.012" - .030"	2 - .015" 1 - .006"	.015"
M, N32	.015" - .036"	2 - .015" 1 - .006"	.015"
M, N32E	.015" - .036"	2 - .015" 1 - .006"	.020"

FIGURE 13 - GASKET TABLE

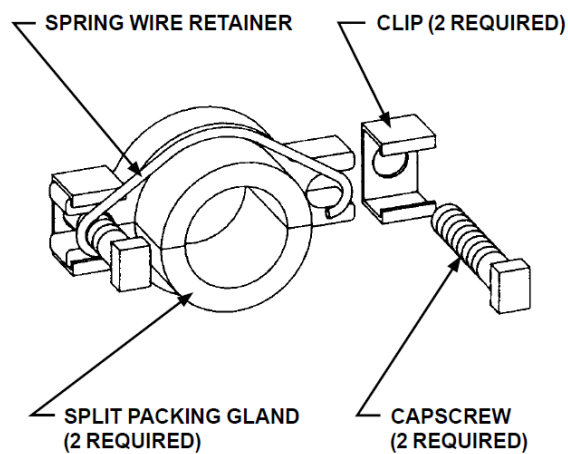

FIGURE 14

To pack the pump with new packing, follow these steps:

1. Place the packing retainer washer in the bottom of the packing chamber. This washer will provide support for the packing material.
2. Choose the appropriate packing material suitable for the liquid being pumped. Ensure that the packing material is compatible with the specific pump and fluid.
3. Install the packing rings, staggering the joints from one side of the shaft to the other. This helps to ensure a proper seal. Start by inserting the first packing ring and push it down firmly into the packing chamber.
4. Lubricate the packing rings with oil, grease, or graphite to aid in the assembly process. This lubrication helps reduce friction and facilitates the proper seating of the rings.
5. Use a length of pipe or a suitable tool to carefully seat each packing ring. Apply gentle pressure to ensure that the packing is compressed and forms a tight seal around the shaft.

Continue this process until all the required packing rings have been installed and properly seated in the packing chamber. Make sure that the packing material is evenly distributed and securely in place.

By following these steps, you can effectively pack the pump with new packing material, ensuring a reliable and efficient seal to prevent leaks during operation. **NOTE: IF THE PUMP HAS A LANTERN RING IT MUST BE LOCATED BELOW THE GREASE FITTING. THE GREASE FITTING MAY BE REMOVED TO FACILITATE THE POSITIONING OF THE LANTERN RING.**

To install the packing gland, capscrews, and nuts, please follow these steps:

1. Take the packing gland, which is a threaded collar, and place it over the packing material that has been previously installed in the packing chamber. Ensure that it is aligned properly with the shaft.
2. Insert the capscrews through the designated holes on the packing gland. These capscrews are used to secure the gland in place.
3. Screw the nuts onto the capscrews and begin tightening them evenly using a suitable wrench or tool. Gradually tighten the nuts in a crisscross pattern, alternating between the capscrews, to ensure even pressure distribution.
4. Continue tightening the nuts until the packing gland is snugly and securely fastened, but avoid over-tightening, as it may lead to excessive compression of the packing material.
5. Double-check that all the capscrews and nuts are properly tightened and secure.

The packing gland, capscrews, and nuts play a crucial role in creating a seal around the shaft and preventing leakage. By following these steps, you can successfully install these components and complete the packing gland assembly of the pump.

DANGER !

Before starting pump, be sure all drive equipment guards are in place.

Failure to properly mount guards may result in serious injury or death.

NOTE: PUMP MAY BE EQUIPPED WITH A 2-PIECE SPLIT PACKING GLAND. SEE FIGURE 14.

MECHANICAL SEAL OPTION

To install the mechanical seal in the pump, please follow these steps:

1. Begin by placing the set collar on the shaft in the location indicated in Figure 15 on page 9. Tighten the set screw to secure the set collar in place. The set collar helps to position and support the mechanical seal.
2. Take care during the installation process to ensure good performance of the seal. The mechanical seal relies on complete contact between the rotary and stationary members, which are lapped to a high finish.
3. Once the rotating position of the mechanical seal is determined and installed on the rotor shaft, it is important to assemble the remaining parts quickly to prevent the seal from sticking to the shaft in the wrong axial position. The seal may adhere to the shaft after a few minutes of setting time.
4. Handle the sealing faces with clean hands or a clean cloth only. Avoid touching the faces with anything that could scratch them, as minute particles can cause leakage.

5. Place the spring washer and spring onto the shaft in that order, as shown in Figure 15.
6. Apply a film of lubricating oil to the inside diameter of the synthetic rubber bellows. Inspect the end of the pump shaft for any sharp burrs or edges that could potentially damage the bellows. Carefully slide the seal rotary member over the shaft and up against the spring.
7. Coat the synthetic rubber seal seat with lubricating oil and insert the seal seat into the end cap. Place the end cap gasket onto the end of the casing.
8. Slide the end cap over the shaft, ensuring that both the seal seat and the carbon wear ring in the seal rotary member are flushed with oil. Push the end cap up until the mating surfaces of the seal meet.
9. Install the capscrews and tighten them evenly to secure the end cap in place. Make sure the capscrews are tightened sufficiently but avoid over-tightening.

By following these steps, you can properly install the mechanical seal in the pump, ensuring good performance and preventing leakage.

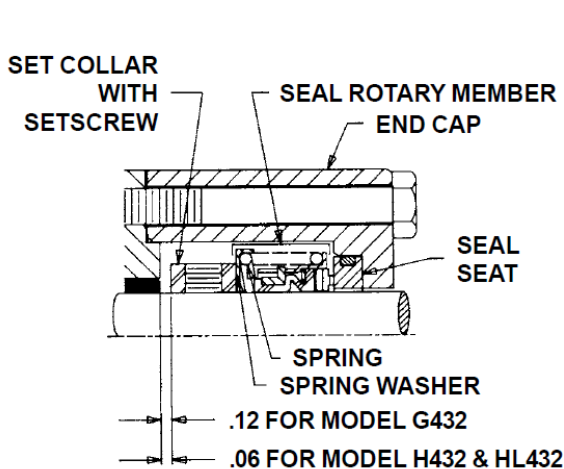

FIGURE 15 - SECTIONAL VIEW, SEAL AREA

PRESSURE RELIEF VALVE INSTRUCTIONS

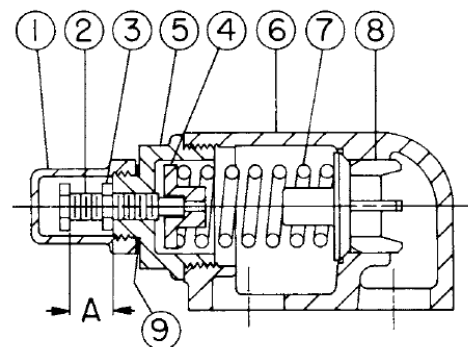

FIGURE 16 - SIZE G, H AND HL

VALVE - LIST OF PARTS

1. Valve Cap	6. Valve Body
2. Adjusting Screw	7. Valve Spring
3. Lock Nut	8. Poppet
4. Spring Guide	9. Cap Gasket
5. Bonnet	10. Bonnet O-ring

INSTALLATION OF CARBON GRAPHITE BUSHINGS

When installing carbon graphite bushings, it is crucial to handle them with care to prevent breakage. Follow these precautions for proper installation:

1. Use a press: Ensure that a press is utilized for the installation process. This will provide controlled and uniform pressure.

2. Start straight: Begin the installation by aligning the bushing straight with the mating part. This will help prevent any misalignment or damage during the insertion process.
3. Continuous pressing: Maintain a consistent pressing operation without stopping until the bushing is fully in place. Starting and stopping the pressing operation can lead to cracks in the bushing.
4. Post-installation inspection: After the bushing is installed, carefully examine it for any signs of cracks. Inspecting the bushing ensures that it is intact and ready for use.

Additionally, applying a lubricant to the bushing and adding a chamfer (beveled edge) on both the bushing and the mating part can assist in the installation process by reducing friction and facilitating alignment.

By following these precautions, you can minimize the risk of breakage and ensure the successful installation of carbon graphite bushings.

Carbon graphite bushings with extra interference fit are frequently furnished for high-temperature operation. These bushings must be installed by a shrink fit.

1. Heat the bracket or idler to 750F (400C) and no higher than 1,000F (535C) in a non-oxidizing environment.
2. Install cool bushings with a press.
3. If facilities are not available to reach 750F temperature, it's possible to install with 450F temperature, however, the lower the temperature the greater the possibility of the bushings cracking.

DISASSEMBLY

DANGER!

Before opening any Viking pump liquid chamber (pumping chamber, reservoir, relief valve adjusting cap fitting, etc.) Be sure:

1. That any pressure in the chamber has been completely vented through the suction or discharge lines or other appropriate openings or connections.
2. That the driving means (motor, turbine, engine, etc.) has been "locked out" or made non-operational so that it cannot be started while work is being done on the pump.
3. That you know what liquid the pump has been handling and the precautions necessary to safely handle the liquid. Obtain a material safety data sheet (MSDS) for the liquid to be sure these precautions are understood.

Failure to follow above listed precautionary measures may result in serious injury or death.

When disassembling the valve, it is important to mark the valve and head to ensure proper reassembly. Follow these steps:

1. Remove the valve cap.
2. Measure and record the length of extension of the adjusting screw. This measurement can be referred to as "A" on Figures 16, 17, and 18 on page 9 of the manual.
3. Loosen the locknut and back out the adjusting screw until the spring pressure is released.
4. Remove the bonnet, spring guide, spring, and poppet from the valve body.
5. Thoroughly clean and inspect all the disassembled parts for wear or damage. Replace any parts that are worn or damaged.

Remember to handle the components with care and keep them in a clean and organized manner during the disassembly process to ensure proper reassembly later.

ASSEMBLY

DANGER!

Before starting the pump, be sure all drive equipment guards are in place.

Failure to properly mount guards may result in serious injury or death.

To reassemble the valve, follow the reverse procedures outlined under disassembly. Here are the steps:

1. Replace the poppet, spring, spring guide, and bonnet into the valve body.
2. Tighten the adjusting screw until it is snug but not fully tightened.
3. Using the recorded measurement from step 2 of the disassembly process, extend the adjusting screw to the same length as before. Refer to "A" on Figures 16, 17, and 18 on page 9 for guidance.
4. Securely tighten the locknut to lock the adjusting screw in place.
5. Ensure that the relief valve adjusting screw cap is pointing towards the suction side of the pump. This orientation is important for proper functioning.
6. If the pump rotation is reversed, remove the relief valve and turn it end for end to adjust its orientation accordingly. Refer to Figures 1, 2, and 4 for guidance.

Make sure all components are securely tightened and properly aligned during reassembly. Follow any additional instructions provided in the manual to complete the reassembly process accurately.

PRESSURE ADJUSTMENT

If you need to install a new spring or adjust the pressure setting of a pressure relief valve, please follow these instructions:

1. Install a pressure gauge in the discharge line to monitor the actual adjustment operation. Avoid deadheading the pump (operating with a closed discharge line) for more than 30 seconds at a time.
2. Carefully remove the valve cap that covers the adjusting screw.
3. Loosen the locknut that secures the adjusting screw to prevent the pressure setting from changing during pump operation.
4. Turn the adjusting screw clockwise to increase the pressure or counterclockwise to decrease the pressure. Make gradual adjustments to achieve the desired pressure setting.
5. With the discharge line closed at a point downstream of the pressure gauge, observe the maximum pressure indicated by the gauge while the pump is in operation. This will allow you to determine the pressure setting of the relief valve.

Remember to take caution and follow proper safety procedures when working with pressure relief valves and adjusting the pressure settings. If you are unsure or inexperienced, it is advisable to seek assistance from a qualified professional.

IMPORTANT

In ordering parts for pressure relief valve, always give model number and serial number of pump as it appears on nameplate and name of part wanted. When ordering springs, be sure to give pressure setting desired.

LIMITED WARRANTY

LIMITED WARRANTY: Each machine manufactured by Thermo-Lay Manufacturing (or “the Company”) is warranted against defects in material and workmanship for a period of twelve (12) months, provided the machine is used in a normal and reasonable manner and in accordance with all operating instructions. In addition, certain machines and components of certain machines have extended warranties as set forth below. If sold to an end user for rental purposes, the applicable warranty period commences from the date of delivery to the end user. If used for rental purposes, the applicable warranty period commences from the date the machine is first made available for rental by the Company or its representative. The limited warranty may be enforced by any subsequent transferee during the warranty period. This limited warranty is the sole and exclusive warranty given by the Company.

EXCLUSIVE REMEDY: Should any warranted product fail during the warranty period, the Company will cause it to be repaired or replaced, as the Company may elect, any part or parts of such machine that the Company’s examination discloses to be defective in material or factory workmanship. Repairs or replacements are to be made at the selling Thermo-Lay Manufacturing distributor’s location or at other locations approved by the Company. In lieu of repair or replacement, the Company may elect, at its sole discretion, to refund the purchase price of any product deemed defective. The foregoing remedies shall be the sole and exclusive remedies of any party making a valid warranty claim.

This Limited Warranty shall not apply to (and the Company shall not be responsible for):

1. Major components or trade accessories that have a separate warranty from their original manufacturer, such as, but not limited to, trucks, engines, hydraulic pumps, motors, tires, and batteries.
2. Normal adjustments and maintenance services.
3. Normal wear parts such as, but not limited to, oils, fluids, light bulbs, fuses, and gaskets.
4. Failures resulting from the machine being operated in a manner or for a purpose not recommended by the Company.
5. Repairs, modifications, or alternations without the express written consent of the Company, which in the Company’s sole judgment, have adversely affected the machine’s stability, operation, or reliability as originally designed and manufactured.
6. Items subject to misuse, negligence, accident, or improper maintenance.

NOTE The use in the product of any parts other than parts approved by the Company may invalidate this warranty. The Company reserves the right to determine, in its sole discretion, if the use of non-approved parts operates to invalidate the warranty. Nothing contained in this warranty shall make the Company liable for loss, injury, or damage of any kind to any person or entity resulting from any defect or failure of the machine.

THIS WARRANTY SHALL BE IN LIEU OF ALL OTHER WARRANTIES, EXPRESSED, OR IMPLIED. INCLUDING WITHOUT LIMITATION, ANY IMPLIED WARRANTIES OF MERCHANTABILITY OR FITNESS FOR A PARTICULAR PURPOSE, ALL OF WHICH ARE DISCLAIMED.

This warranty is in lieu of all other obligations or liabilities, contractual and otherwise, on the part of the Company. For the avoidance of doubt, the Company shall not be liable for any indirect, special, incidental, or consequential damages, including but not limited to, loss of use or lost profits. The Company makes no representation that the machine has the capacity to perform any functions other than as contained in the Company’s literature, catalogs, or specifications accompanying the delivery of the machine. No person or affiliated company representative is authorized to alter the terms of this warranty, to give any other warranties, or to assure any other liability on behalf of the Company in connection with the sales, servicing, or repair of any machine manufactured by the Company. Any legal action based hereon must be commenced within twelve (12) months of the event or facts giving rise to such action.

The Company reserves the right to make design changes or improvements to its products without imposing any obligation upon itself to change or improve previously manufactured products.



Thermo-Lay Manufacturing
1953 E. Commercial Street, Meridian, ID 83642
406-259-9525
www.thermo-lay.com | info@thermo-lay.com

WARRANTY

The warranty administrator at Thermo-Lay Manufacturing may be reached in the following ways:

Telephone: 406-259-9525
Email: Parts@Thermo-Lay.com
Email: Info@Thermo-Lay.com

Thermo-Lay Manufacturing
Attn: Warranty Department
1953 E. Commercial Street
Meridian, ID 83642

Parts requested under the warranty will be shipped with the understanding that the defective or failed parts are to be returned to Thermo-Lay within thirty (30) days. When parts are requested, the Warranty Department will require the equipment's serial number and a brief description of the failure or defect. The equipment's serial number and a brief description of the failure or defect MUST accompany any part being returned to the factory for warranty.

PARTS MUST BE RETURNED AND RECEIVED BY THERMO-LAY WITHIN THIRTY (30) DAYS OF THE INITIATION DATE. PARTS NOT RETURNED WITHIN THIRTY (30) DAYS WILL RESULT IN A REJECTION OF THE CLAIM AND THE REPLACEMENT PARTS SHIPPED WILL BE DUE AND PAYABLE.

THE SHIPMENT MUST BE FREIGHT PRE-PAID TO

Thermo-Lay Manufacturing
1953 E. Commercial Street
Meridian, ID 83642

Return C.O.D. shipments will not be accepted. Return freight for approved claims will be reimbursed.

If Thermo-Lay determines that the parts do not need to be returned for warranty processing, the dealer/customer will be notified by email by Thermo-Lay.

Upon receipt of the part(s), Thermo-Lay will inspect the parts to make a determination of warranty. Thermo-Lay will notify the dealer/customer within sixty (60) days of the initiation date of the warranty.

NOTE: FAILURE TO RETURN THE REQUESTED PARTS WITHIN THE SET TIME FRAME WILL VOID THE WARRANTY CLAIM.

EXCLUSIONS AND LIMITATIONS

The warranty labor repair time allowances are based on actual or replacement times only. Warranty repairs are to be performed only at the authorized distributor's location or a facility approved by Thermo-Lay. If a warranty repair is to be completed by someone other than the authorized Thermo-Lay distributor, pre-approval must be obtained. If approval is granted, the warranty claim must clearly indicate who did the work, and a copy of their invoice must be attached electronically to the claim. Any third-party contractor will be allowed only the Standard Repair Time that would have been allowed by the dealer. Travel time will be paid for the actual time, up to a maximum of three (3) hours per claim. Travel hours will be reimbursed at ½ the warranty labor rate established for the dealer. There are no allowances made for the following costs or any similar field service expenses:

EXCLUSIONS AND LIMITATIONS

- Pre-delivery service and checks
- Routine adjustments
- Normal maintenance service
- Mileage
- Towing or hauling
- Fuel
- Phone calls

(EXCLUSIONS AND LIMITATIONS CONTINUED ON NEXT PAGE)



Thermo-Lay Manufacturing
1953 E. Commercial Street, Meridian, ID 83642
406-259-9525
www.thermo-lay.com | info@thermo-lay.com

EXCLUSIONS AND LIMITATIONS CONTINUED

- Administrative fees
- Lodging
- Air freight
- Normal wear items
- Oils, fluids, and filters
- Inspection services
- Testing of repairs
- Repairs due to initial faulty repair.
- Road test of the machine.
- Diagnostic time, except when pre-approved for a qualified operation.
- Dealer freight transfers between locations. The warranty does not apply to the following or any similar failures or costs unless it is the result of being directly damaged by the warrantable failure of a covered component.
- Failures caused by neglect, abuse, accident, misapplication, alterations to the machine after leaving the factory, failures caused by non-Thermo-Lay parts, or acts of vandalism.

WARRANTY REIMBURSEMENT WILL BE ISSUED AS A CREDIT TO THE DEALER/CUSTOMER ACCOUNT.



Thermo-Lay Manufacturing
1953 E. Commercial Street, Meridian, ID 83642
406-259-9525
www.thermo-lay.com | info@thermo-lay.com

